

# Overview of the Basal Ganglia

## Computational Models of Neural Systems

### Lecture 6.1

David S. Touretzky  
November, 2025

# Major Components of the Basal Ganglia

- Neostriatum (or Striatum)

- caudate nucleus and putamen, separated by the internal capsule
- ventral striatum (= nucleus accumbens, olfactory tubercle, plus possibly the ventromedial parts of caudate and putamen)

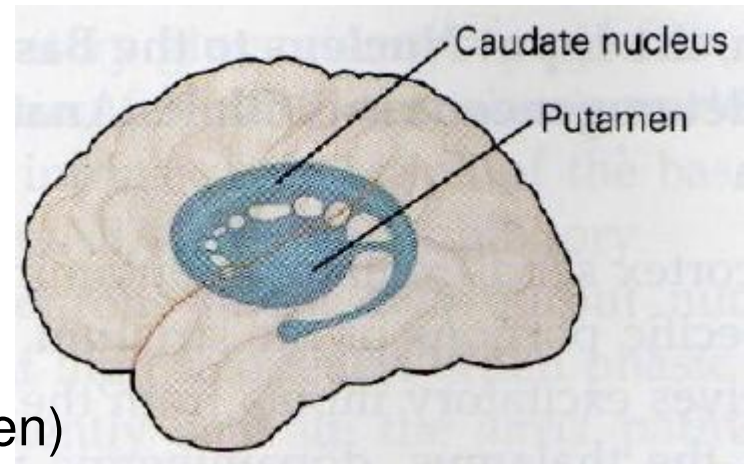

- Globus Pallidus (the pallidum)

- GPe: external segment; GPi: internal segment

- Substantia Nigra

- SNr: Substantia nigra pars reticulata (GABA); similar to GPi
- SNc: Substantia nigra pars compacta (dopamine cells)
  - similar to ventral tegmental area (VTA); is medial extension of SNr

- Subthalamic Nucleus

# Coronal View of Basal Ganglia Components

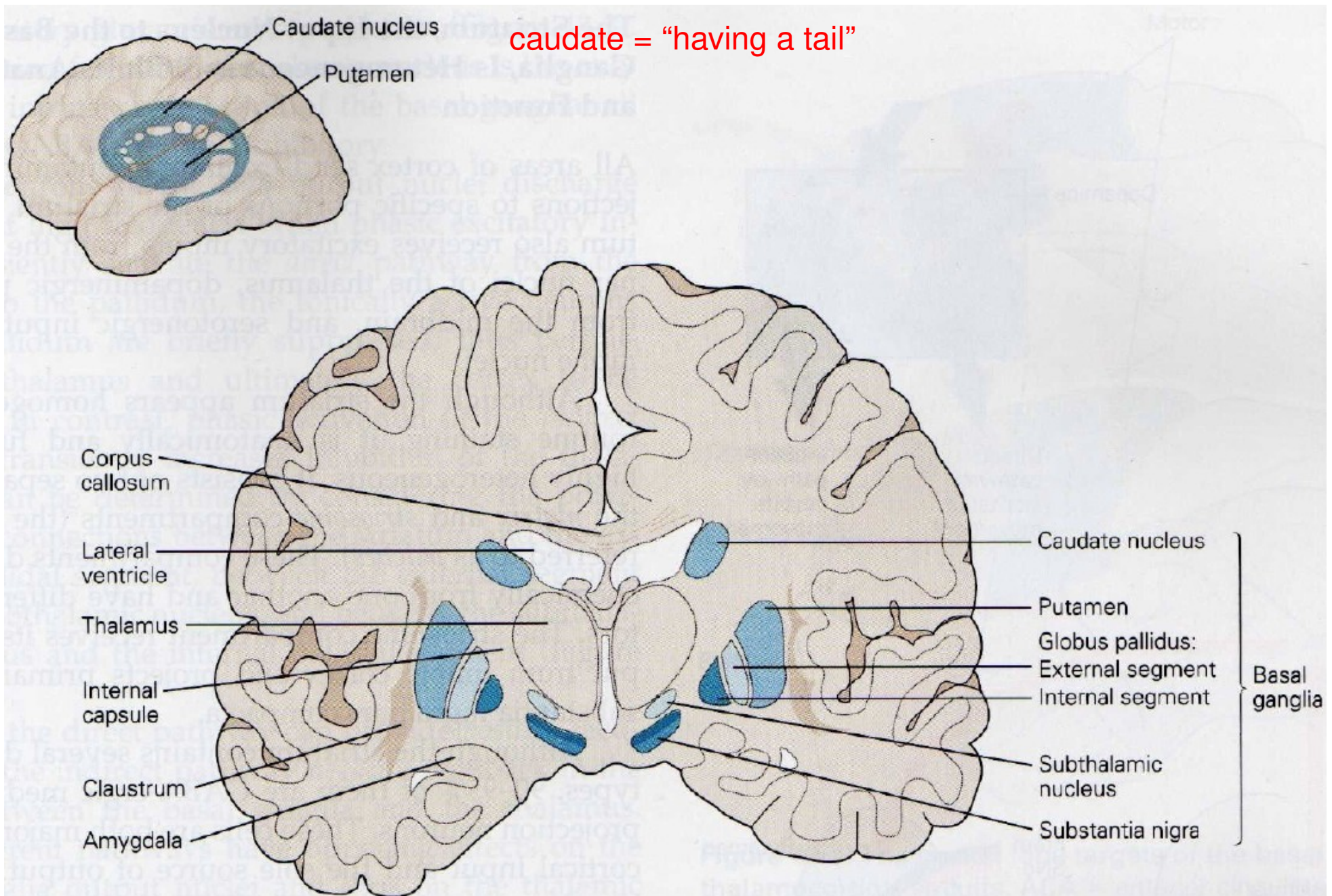

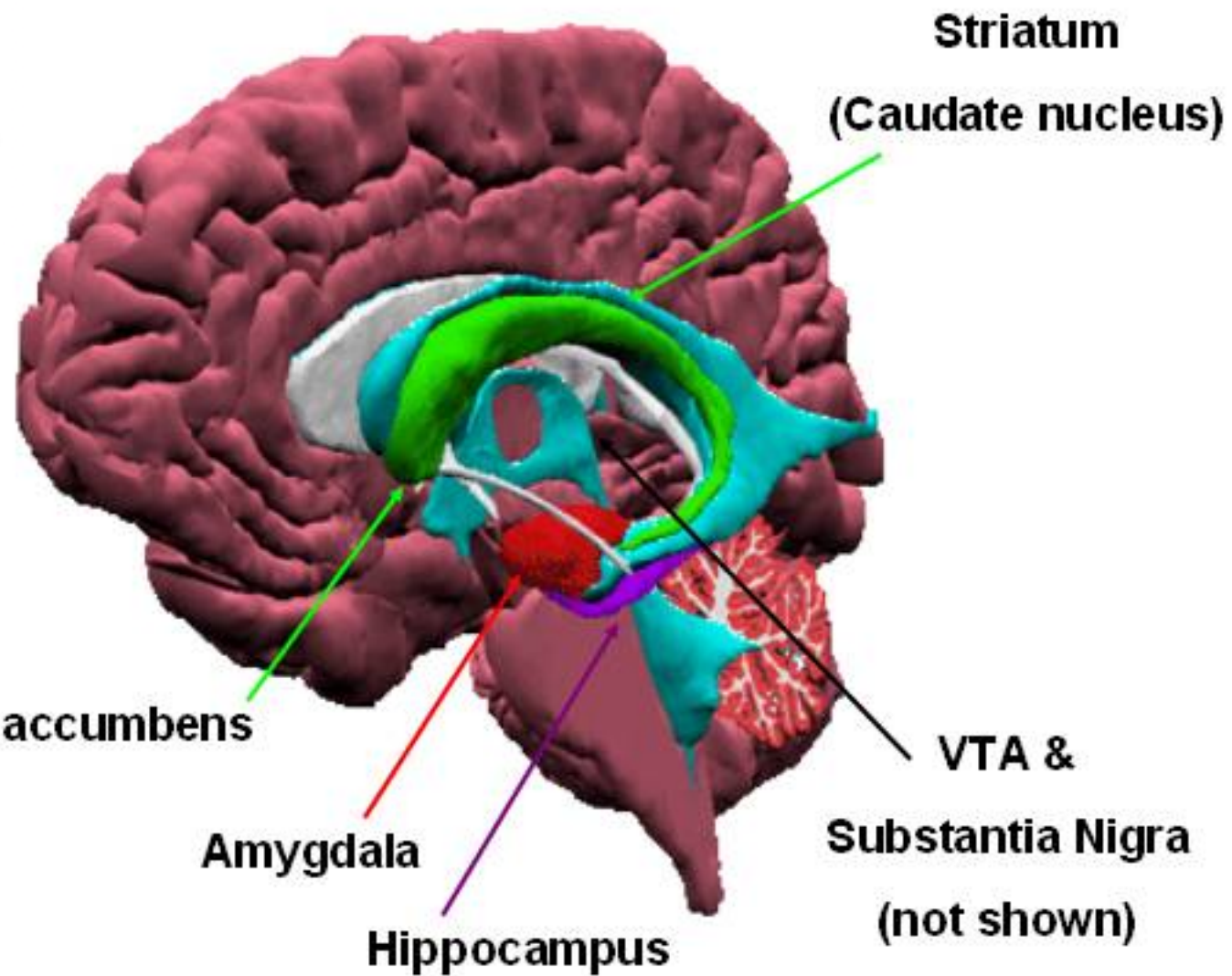
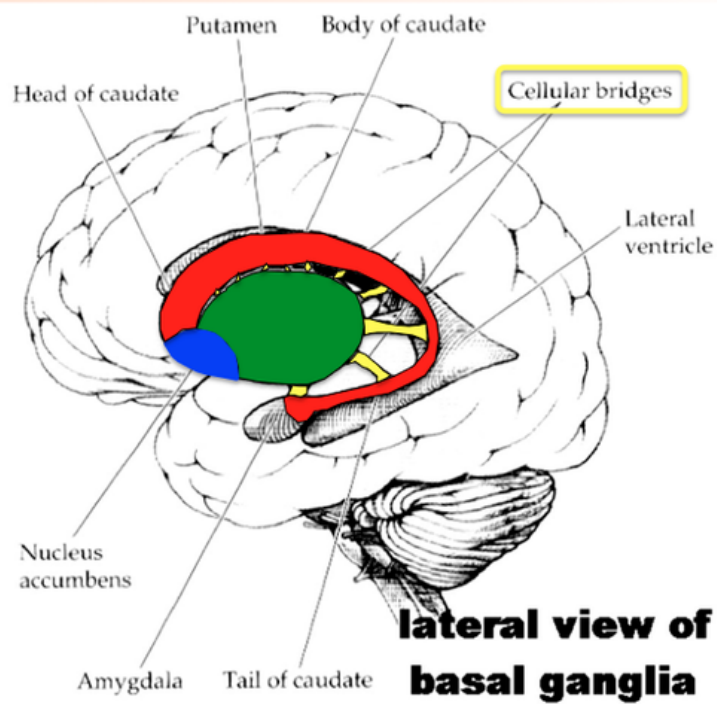

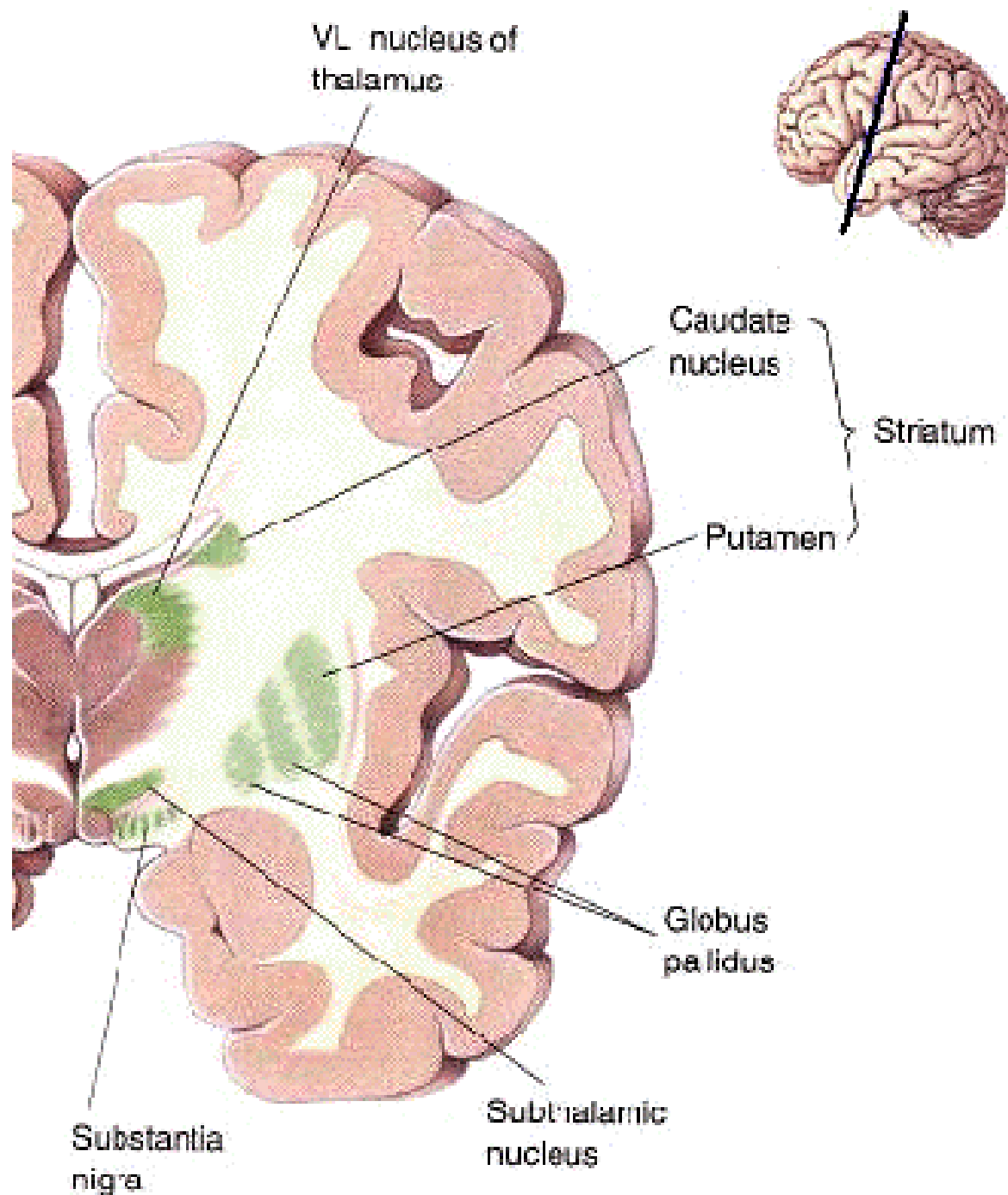

# Multiple Motor Systems: Cortex, BG, Cerebellum

- BG has no direct projection to the spinal cord.
- BG projects to the cortex (including motor areas) via the thalamus.
- Cerebellum also projects to cortex via the thalamus, but the two projections apparently don't overlap.

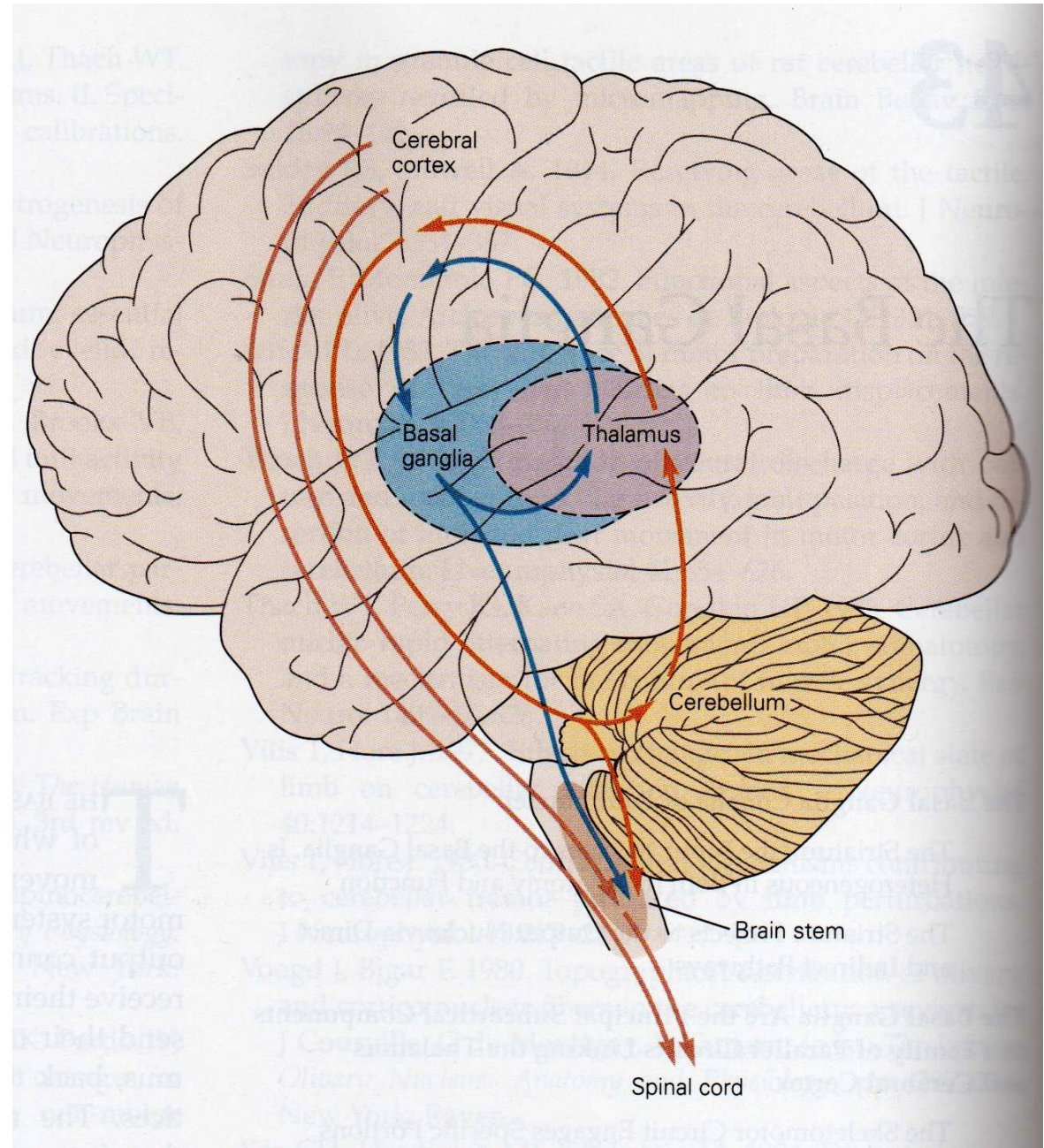

# Cognitive Functions of the Basal Ganglia

- Caudate nucleus:
  - action selection
  - learning and memory; feedback processing
  - habit formation
- Nucleus accumbens:
  - reward; addiction; goal-directed behavior
- Procedural (as opposed to declarative) memory may involve the basal ganglia.

# Habit Formation: Yin and Knowlton, 2006

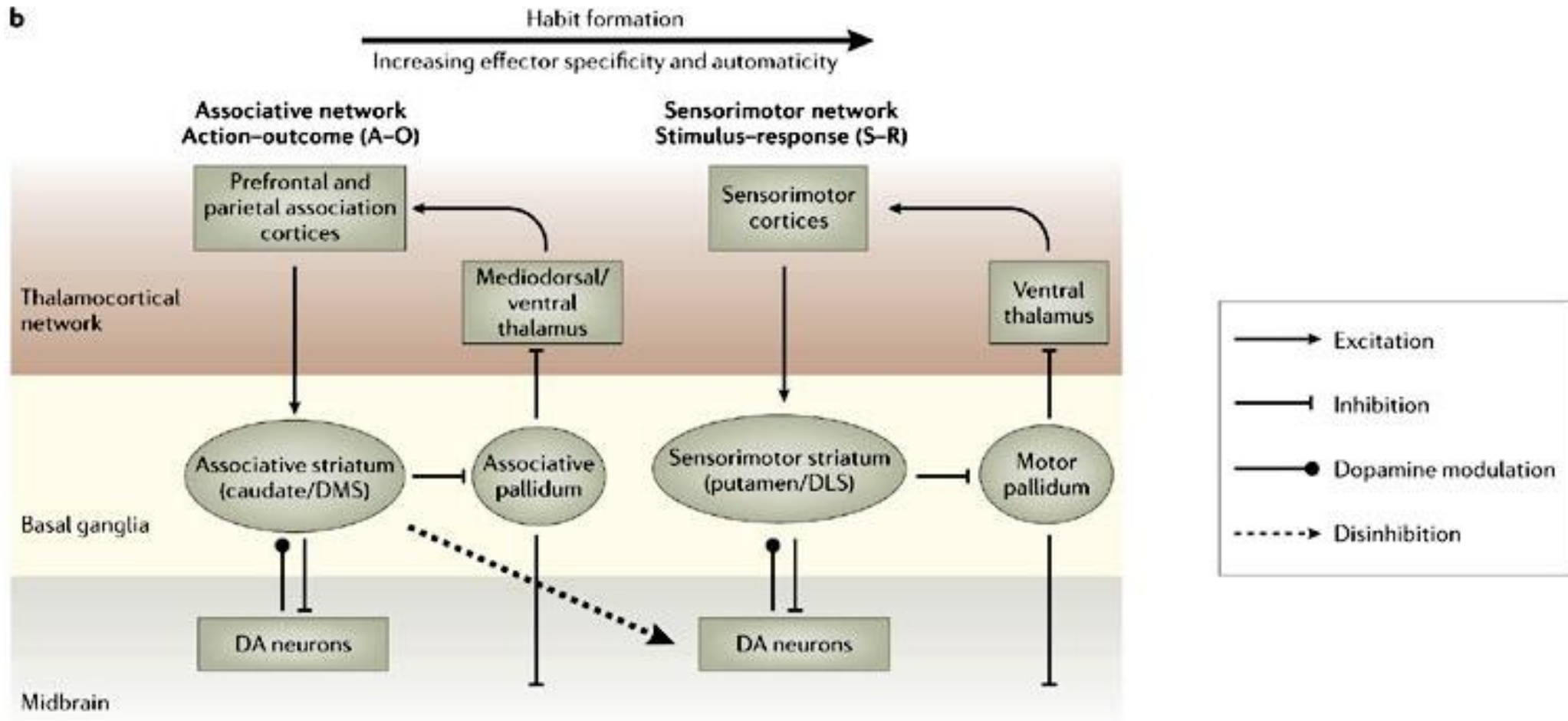

# Habit Formation

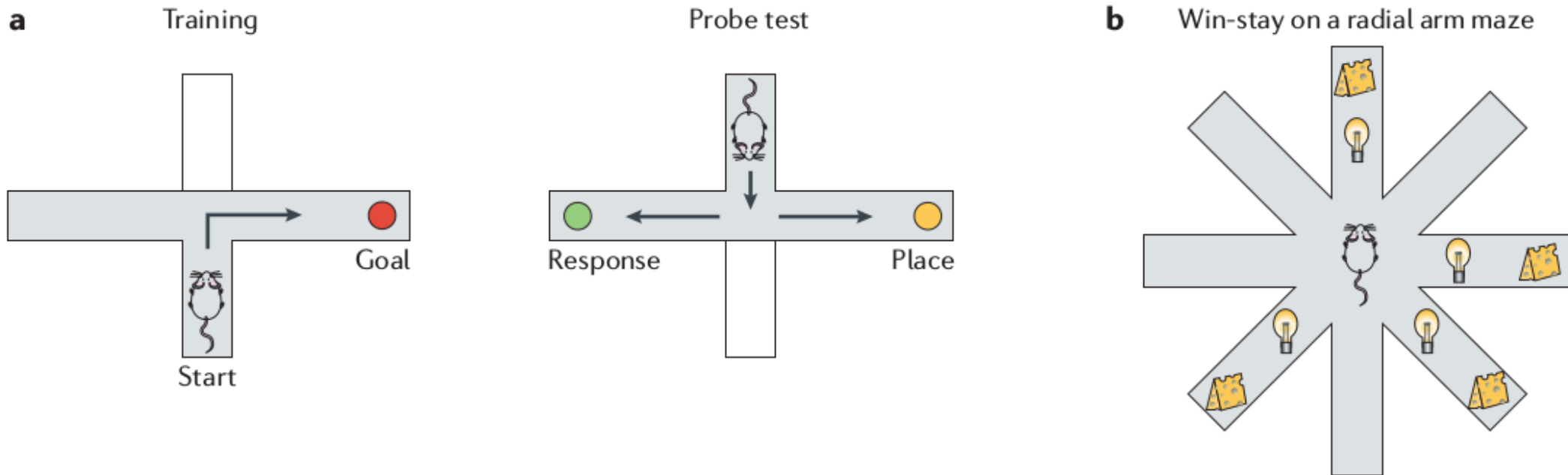

(a) Animal is trained to go to the goal location (right turn).

Probe trial: should animal turn left (to the goal) or right (learned response)?  
Short training: goes to the place. Overtraining: learned response (habit).

(b) Win-stay task: lights mark the baited arms. Animal learns to stick with those arms, which are rebaited after successful visits. Requires dorsal striatum.  
Win-shift task: no lights; arms not rebaited. Requires hippocampus.

# Striatum: Input Stage of the Basal Ganglia

- The striatum (caudate and putamen) is the **input stage** of the basal ganglia.
- Many cortical areas project to the striatum: **100 million fibers** make up the corticostriatal projection.
- Projection is **topographic**: different regions of striatum receive projections from different cortical areas.
- The striatum is also **modulated by a dopaminergic projection** from neurons in SNc and VTA.

# Gpi/SNr: Output Stage of the Basal Ganglia

- GPI and SNr form the output stage of the basal ganglia.
  - Project back to the cortex via the dorsal thalamus.
- **Direct** pathway:  
cortex → striatum → GPI/SNr → thalamus → cortex
- **Indirect** pathway:  
cortex → striatum → **GPe** → **STN** →  
GPI/SNr → thalamus → cortex
- **Dopamine** excites the direct pathway, inhibits the indirect pathway.

# Direct and Indirect Pathways Through BG

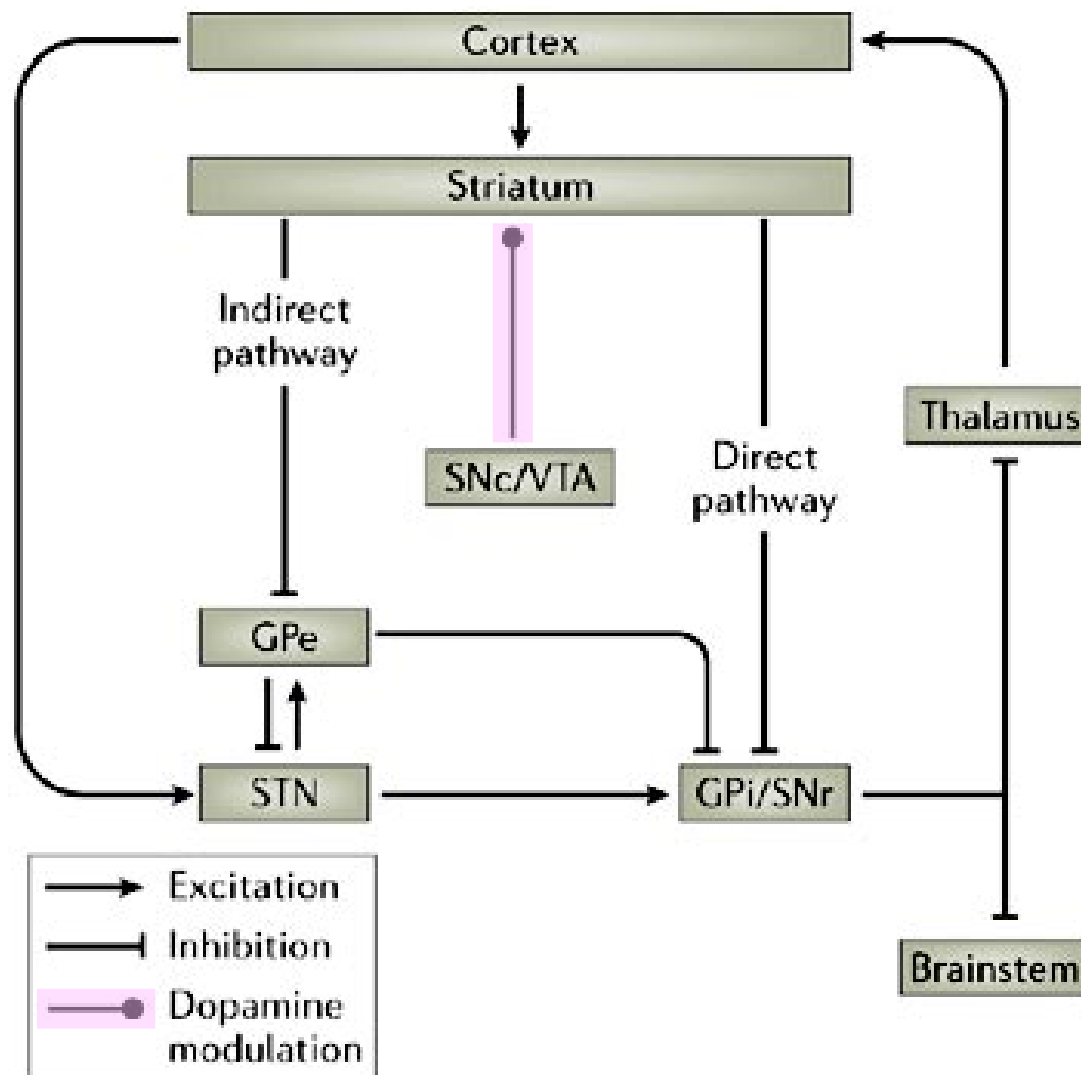

Copyright © 2006 Nature Publishing Group  
Nature Reviews | Neuroscience

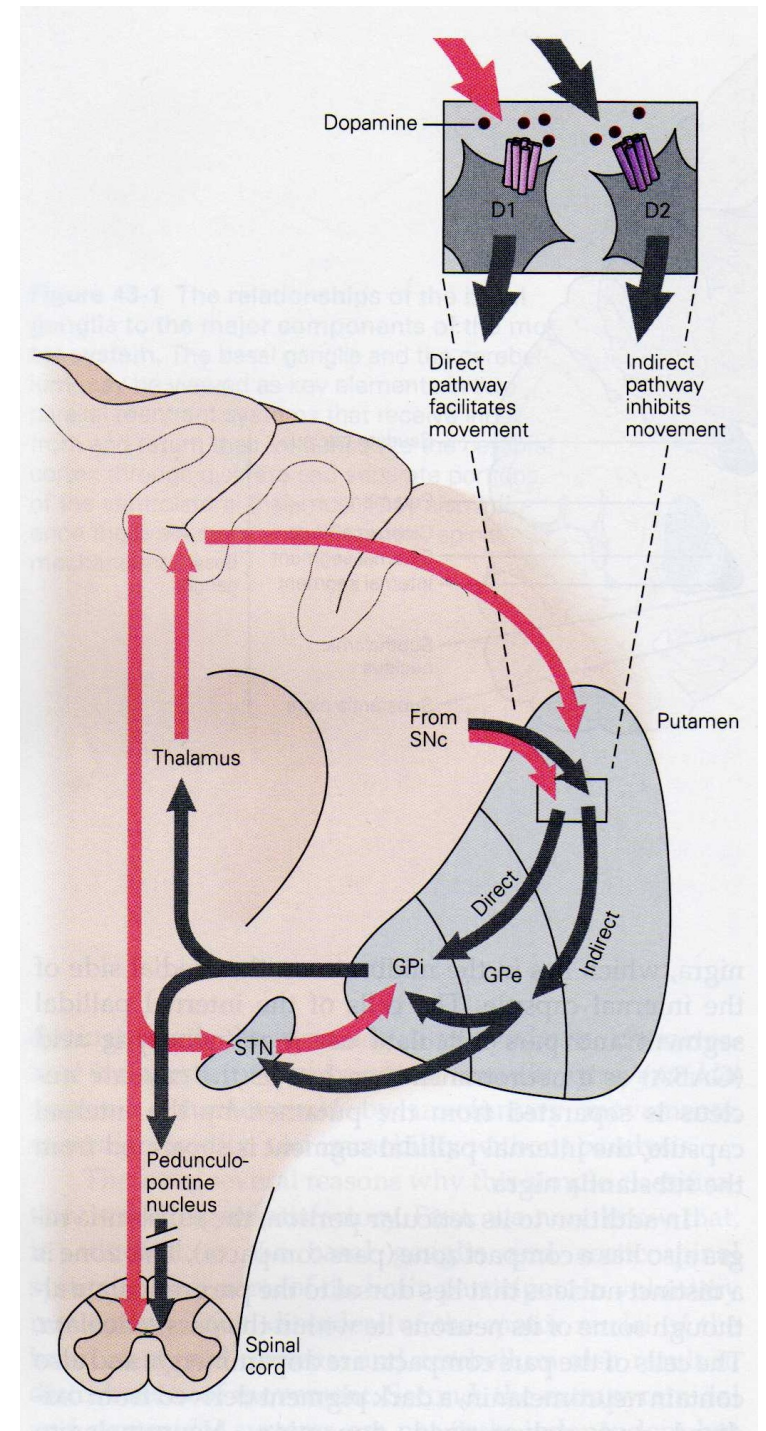
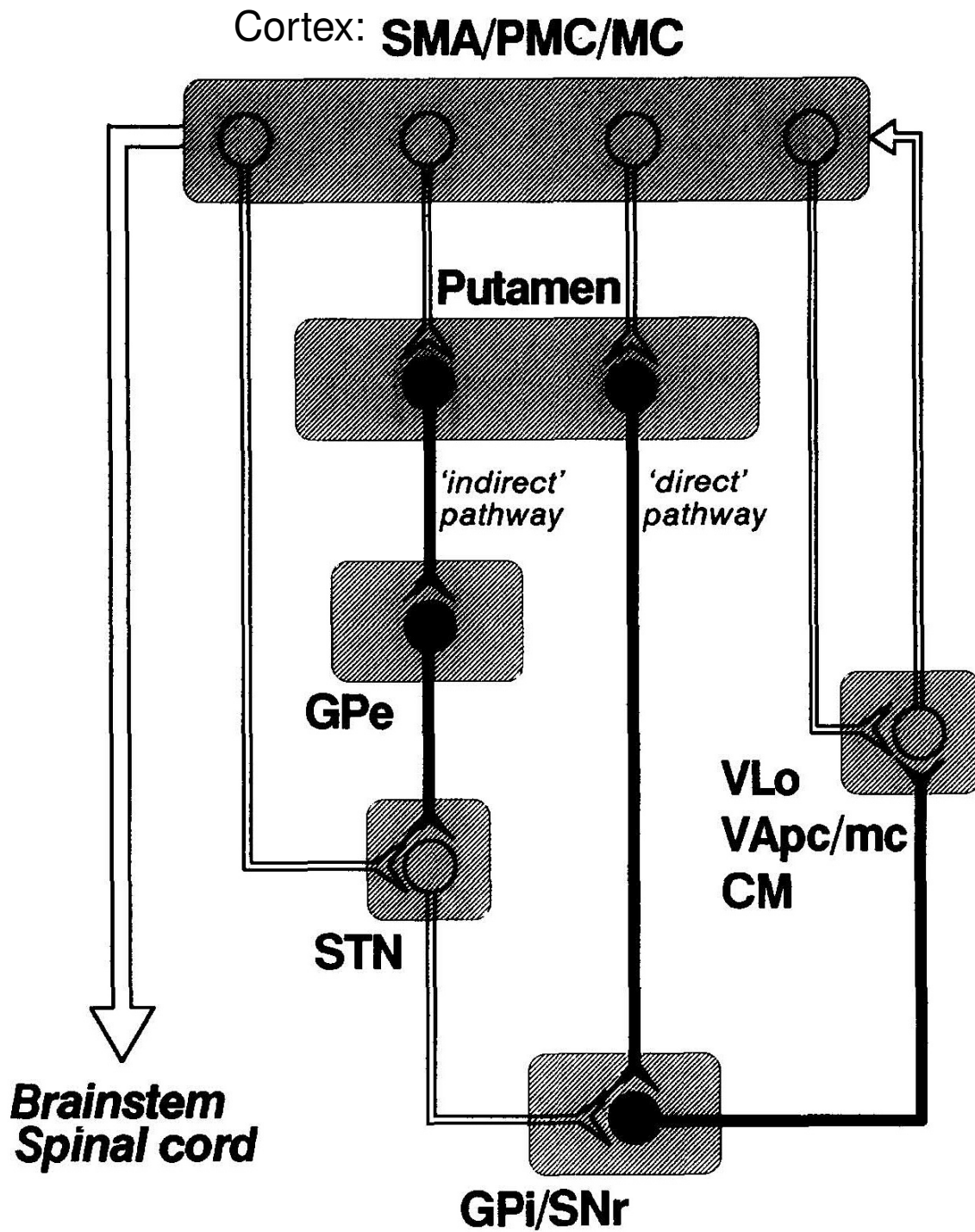

# The Direct Pathway: Facilitates Movement

- Cortical striatal pathway is excitatory, glutamatergic.
  - Striatum has an inhibitory, GABAergic projection to Gpi/Snr. These striatal cells express D1 dopamine receptors.
  - GPi/SNr makes an inhibitory, GABAergic projection to thalamus.
  - Thalamus makes an excitatory projection back to cortex.
- In the direct projection, striatum disinhibits thalamus by inhibiting GPi/SNr.

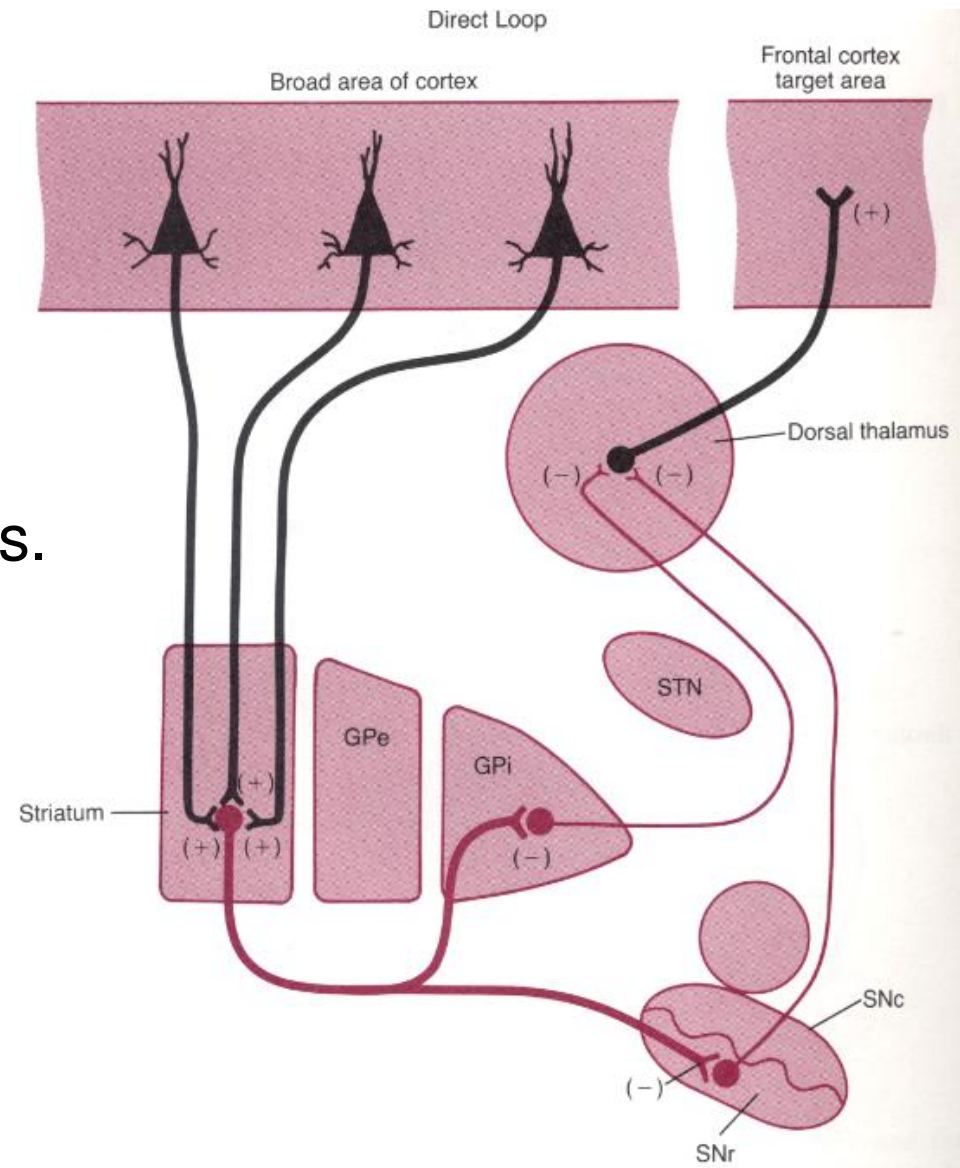

# The Indirect Pathway: Inhibits Movement

- Striatum makes an inhibitory projection to GPe.
- These striatal cells express D2 dopamine receptors.
- GPe inhibits the subthalamic nucleus (STN).
  - So striatum disinhibits STN by inhibiting GPe.
- STN excites GPi/SNr, which inhibits thalamus.

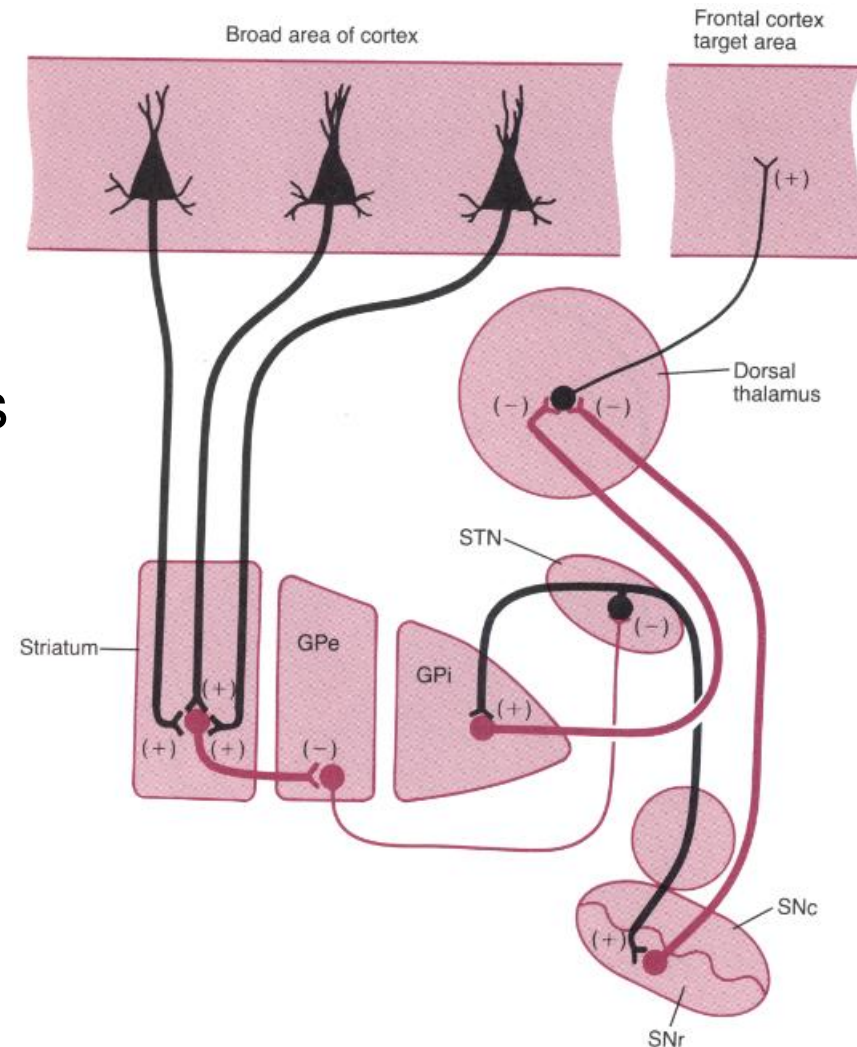

# Direct vs. Indirect Pathways

- Striatum excites GPi/SNr via the indirect pathway, while inhibiting it via the direct pathway.
- Why have opposing signals?
  - Could use inhibitory path to “brake” or “smooth” motor actions initiated by the excitatory path.
  - Could use inhibitory path to suppress other actions that conflict with the action selected via the excitatory path.

# Dopamine Receptors

- D1 family:
  - D1 and D5 receptors
  - G protein coupled receptors (second messenger system)
  - Increases cAMP concentration which leads to phosphorylation of AMPA and NMDA receptors and reduction of potassium conductance.
- D2 family:
  - D2, D3, and D4 receptors.
  - G protein coupled receptors, but different G protein than D1 family
  - D2 is the main receptor for most antipsychotic drugs
  - D2 short form is a pre-synaptic autoreceptor that regulates dopamine release
  - D2 long form is a classic post-synaptic receptor with inhibitory effects via reduction of cAMP concentration

# Striatal Cell Types

- Medium spiny cells
  - Projection neurons from striatum to pallidum and substantia nigra.
  - Neurotransmitter: GABA
- Tonically Active Neurons (TANs)
  - Interneurons with high resting spike rate
  - Neurotransmitter: Acetylcholine (ACh)

# Striatal Compartments

- The striatum contains many irregular, three-dimensional compartments called *striosomes*, embedded within a non-striosomal *matrix*.

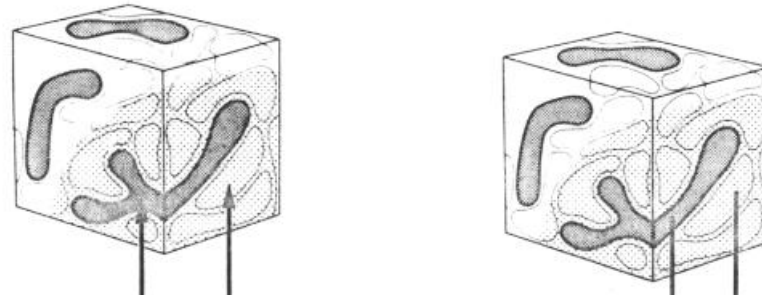

- Neurons in the striosomes project to dopaminergic nuclei (SNc and VTA) that in turn project back to the striatum.
- Striosomes account for 15% of the striatal volume.
- Matrix neurons are the source of the GABA-ergic, inhibitory projections to GPe, GPi, and SNr.

# 5 Parallel Circuits (or 21?)

- Alexander and Crutcher: the basal ganglia appear to be segregated into five circuits receiving projections from, and projecting back to, distinct cortical areas.

1. Motor circuit
2. Oculomotor circuit
3. Limbic circuit
4. Association-1 (DLPFC)
5. Association-2 (LOFC)

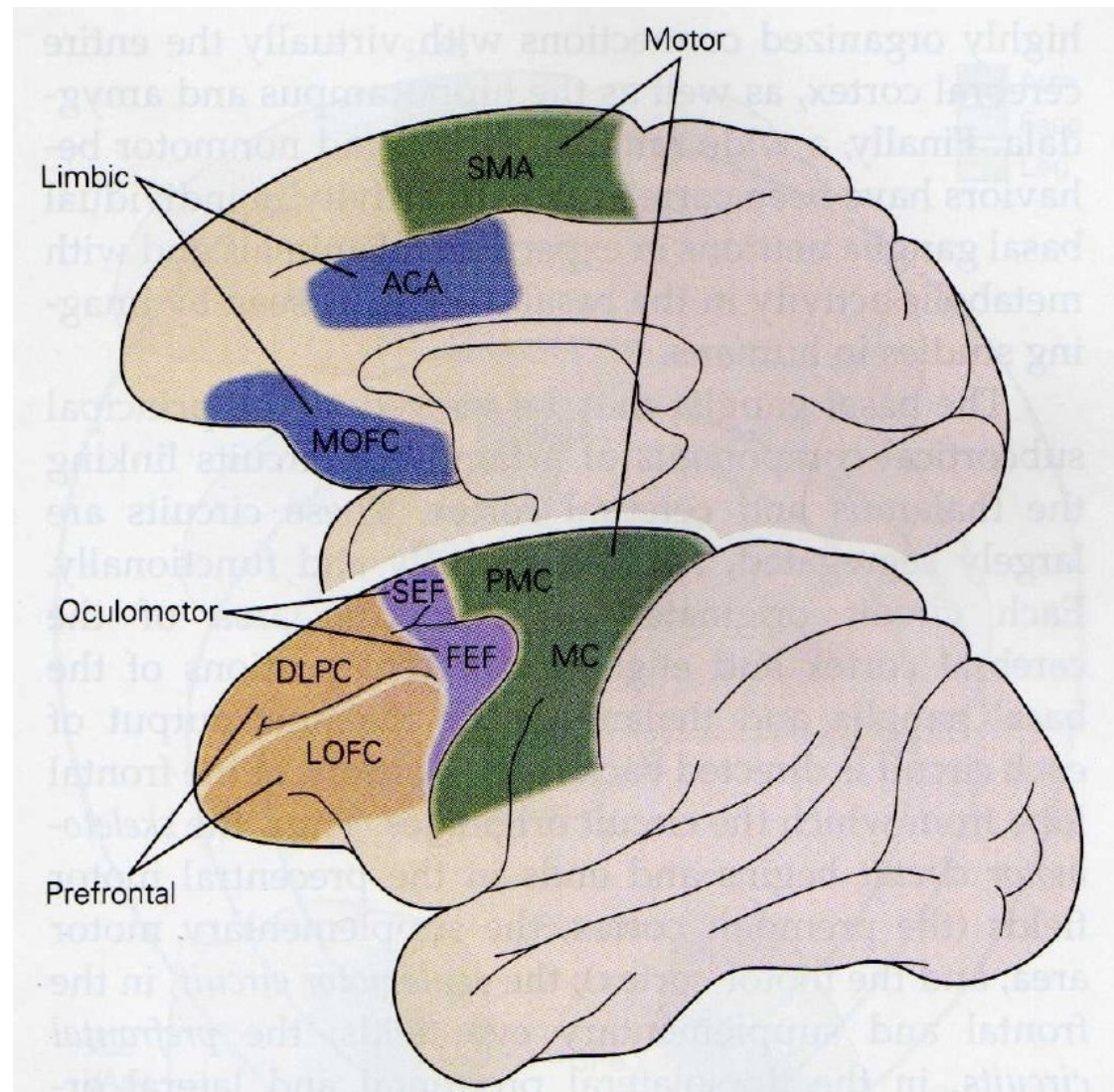

ACA: anterior cingulate area; DLPC: dorsolateral prefrontal cortex; FEF: frontal eye field; LOFC: lateral orbitofrontal cortex; MC: primary motor cortex; MOFC: medial orbitofrontal cortex; PMC: premotor cortex; SEF: supplementary eye field; SMA: supplementary motor area.

# 1. The Motor Circuit

- Corticostriate projection from premotor cortex (PMC), primary motor cortex (M-I), primary somatosensory area (S-I), and parietal motor area (PMA).
- Projection is to the putamen.
- The projection is somatotopic: portions of the limbs and body are represented by oblique strips running the length of the putamen.
- Motor circuit occupies the ventrolateral two thirds of GPe and GPi, and a circumscribed region of SNr.
- Thalamic projections from GPi and SNr end in VA (ventral anterior) and VL<sub>a</sub> (ventral lateral) thalamic nuclei, which project back to cortical motor areas.

# The Motor Circuit

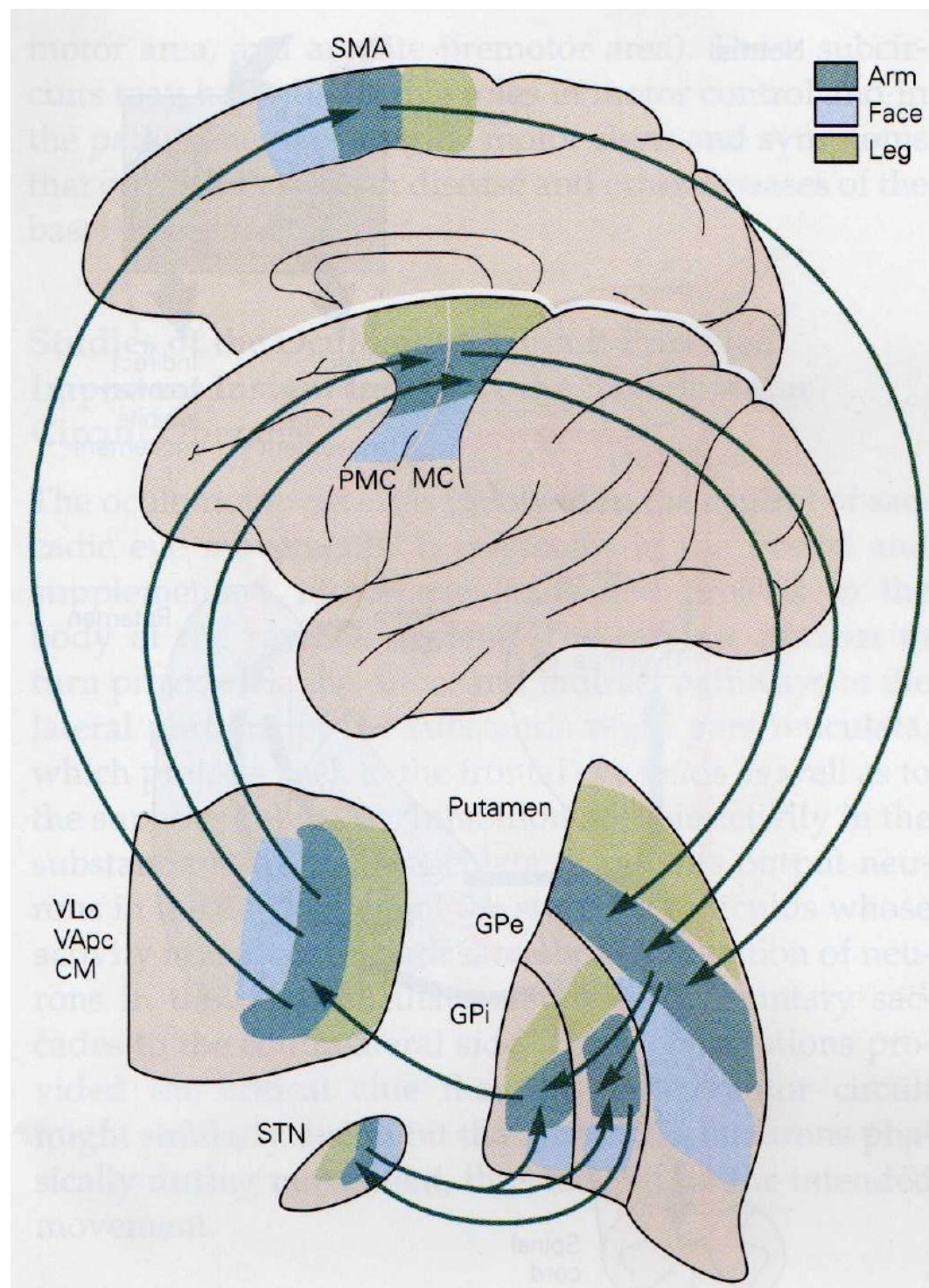

# Middleton & Strick (2000)

\*tentative

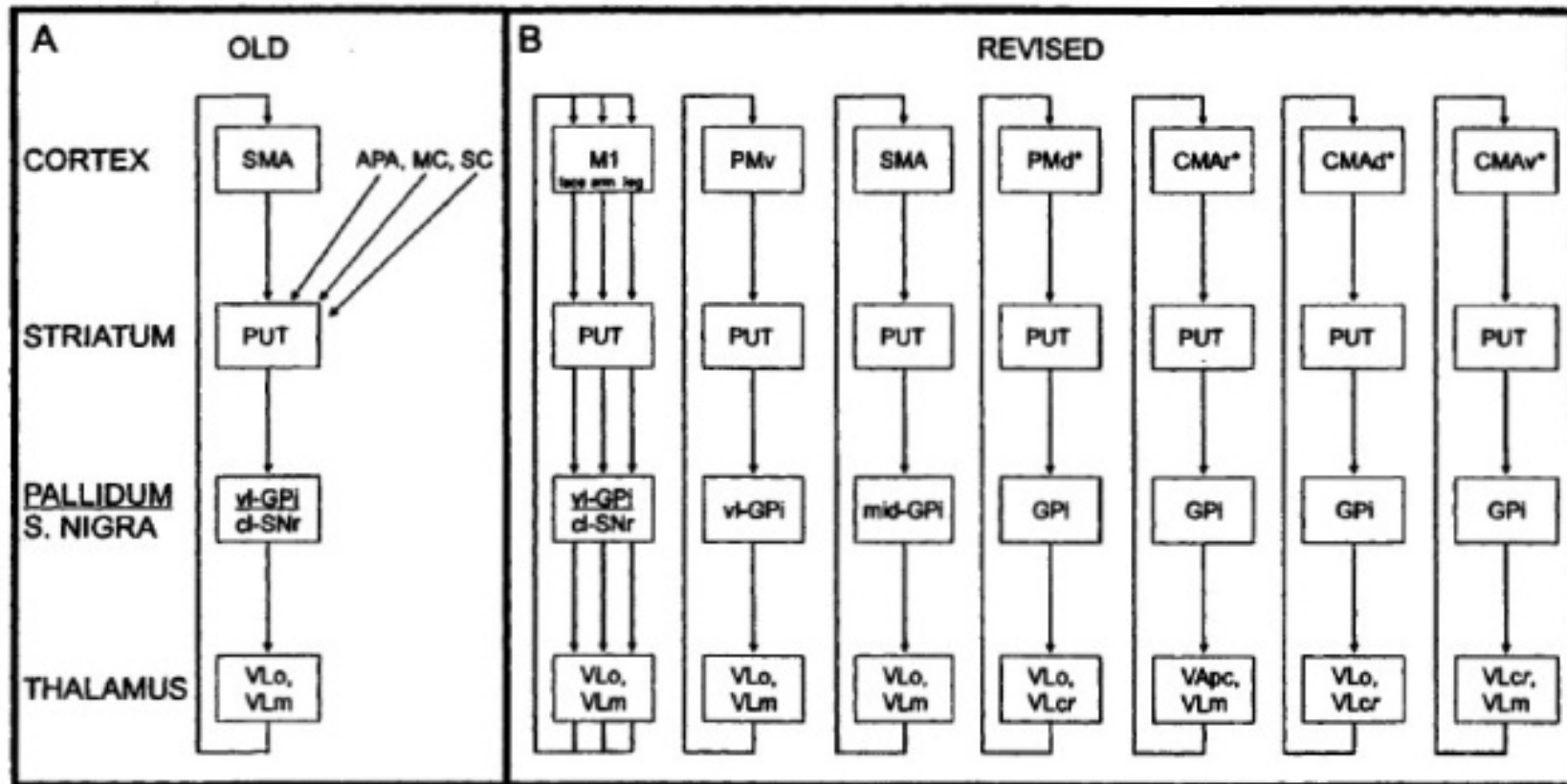

Cortical abbreviations: APA, arcuate premotor area; CMAv, ventral cingulate motor area; CMAr, rostral cingulate motor area; CMAv, ventral cingulate motor area; MC/M1, primary motor cortex; Pmd, dorsal premotor area; Pmv, ventral premotor area; SMA, supplementary motor area. Basal ganglia abbreviations: PUT, putamen; cl, caudolateral; mid, middle; vl, ventrolateral; VApC, nucleus ventralis anterior, parvocellular portion; VLcr, nucleus ventralis lateralis pars caudalis, rostral division; VLm, nucleus ventralis lateralis pars medialis; VLo, nucleus ventralis lateralis pars oralis.

## 2. The Oculomotor Circuit

- Cortical projection to the oculomotor circuit originates in FEF and SEF (frontal and supplementary eye fields), MT (medial temporal area), and PMA.
- Projection is to the body of the caudate.
- Pallidal projection is to the posterior, dorsomedial parts of GPe and GPi.
- Thalamic projection is to medial dorsal nucleus (MD) and VA.
- The returning thalamocortical projection is to the frontal eye field (FEF) and superior colliculus.

# Revised Version: Three Oculomotor Circuits

Saccades      Smooth eye movements

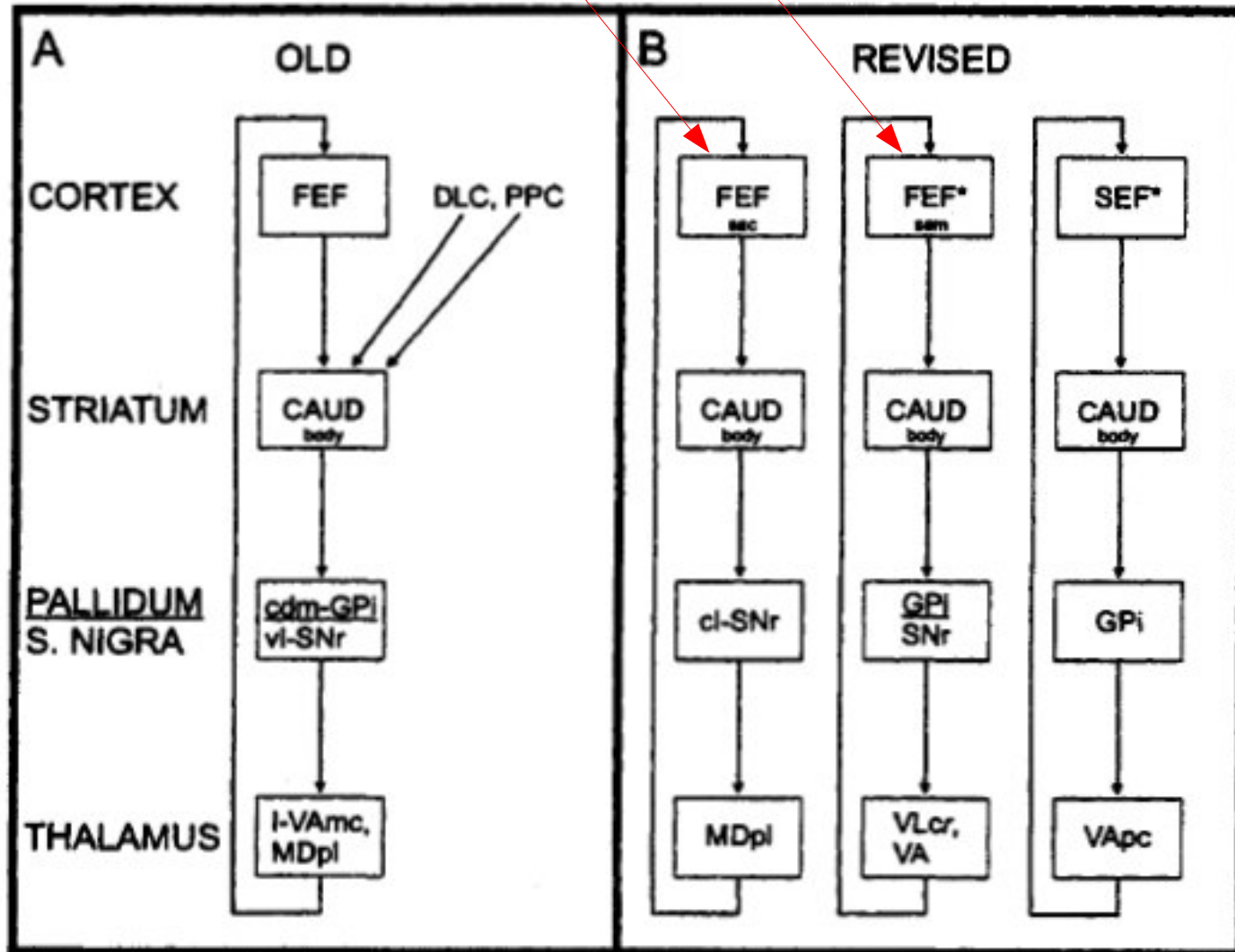

\*tentative

# 3. The Limbic Circuit

- Limbic input is from hippocampus, entorhinal cortex, and superior, middle, and inferior temporal gyri.
- Cortical projection is to the ventral striatum (accumbens).
- Ventral striatum in turn projects to ventral pallidum (GPv).
- Thalamocortical projections are from MD; they terminate in the anterior cingulate (ACA) and medial orbitofrontal (MOFC) areas.
  - More recent data suggests that the thalamocortical projections target the CMAr (rostral cingulate motor area) rather than cingulate gyrus.
  - So this may be more of a motor than a limbic circuit.

# Anterior Cingulate Replaces Limbic Circuit

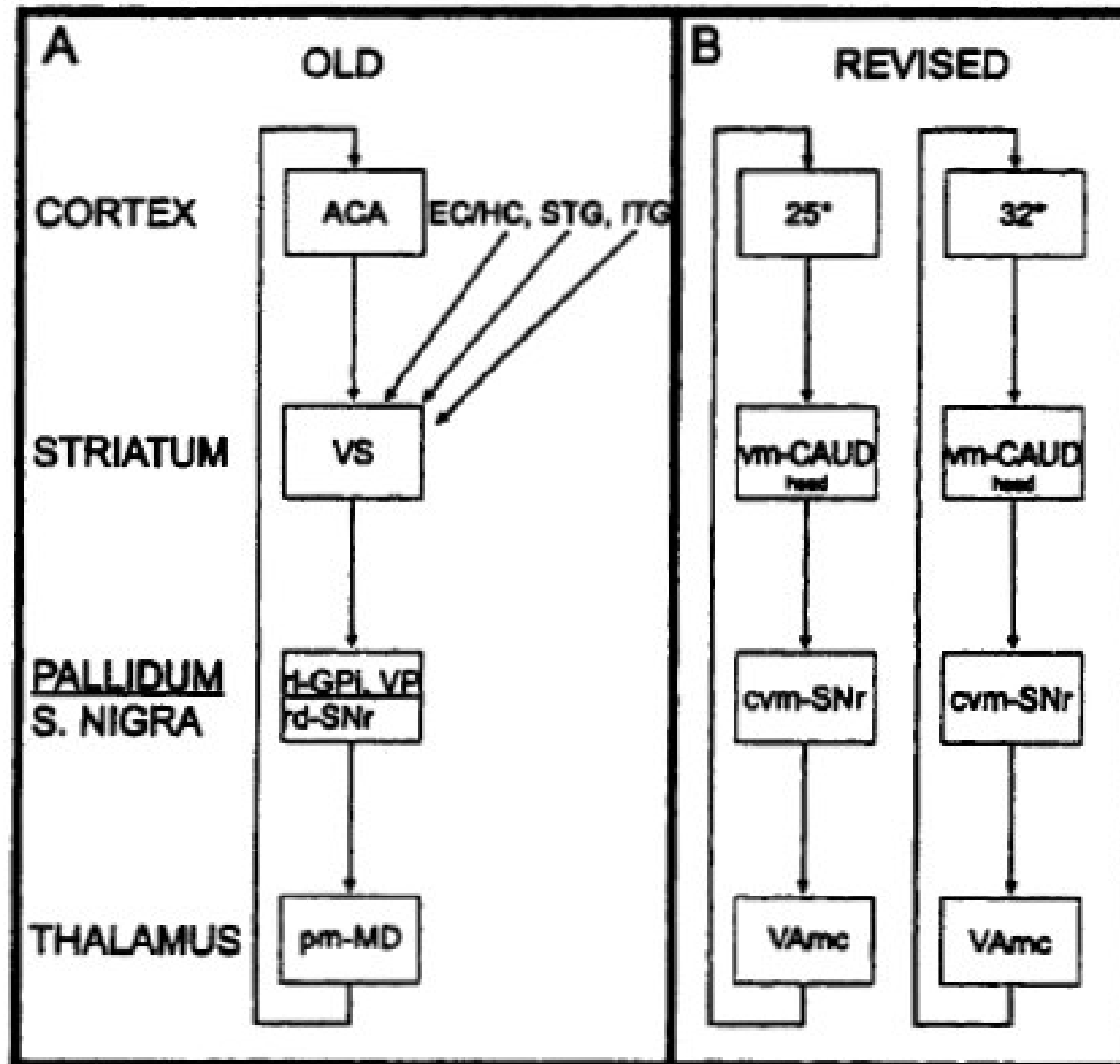

## 4. Prefrontal / Association Circuit 1

- Input from posterior parietal cortex and PMC (pre-motor cortex).
- Corticostriatal projection is to the head of the caudate.
- Pallidal connections are to the dorsomedial third of GPe and GPi.
- Thalamocortical projections from VA and MD terminate in the dorsolateral prefrontal cortex (DLPFC).
- Thought to be involved in aspects of memory related to orientation in space.

# Dorsolateral Prefrontal Loops

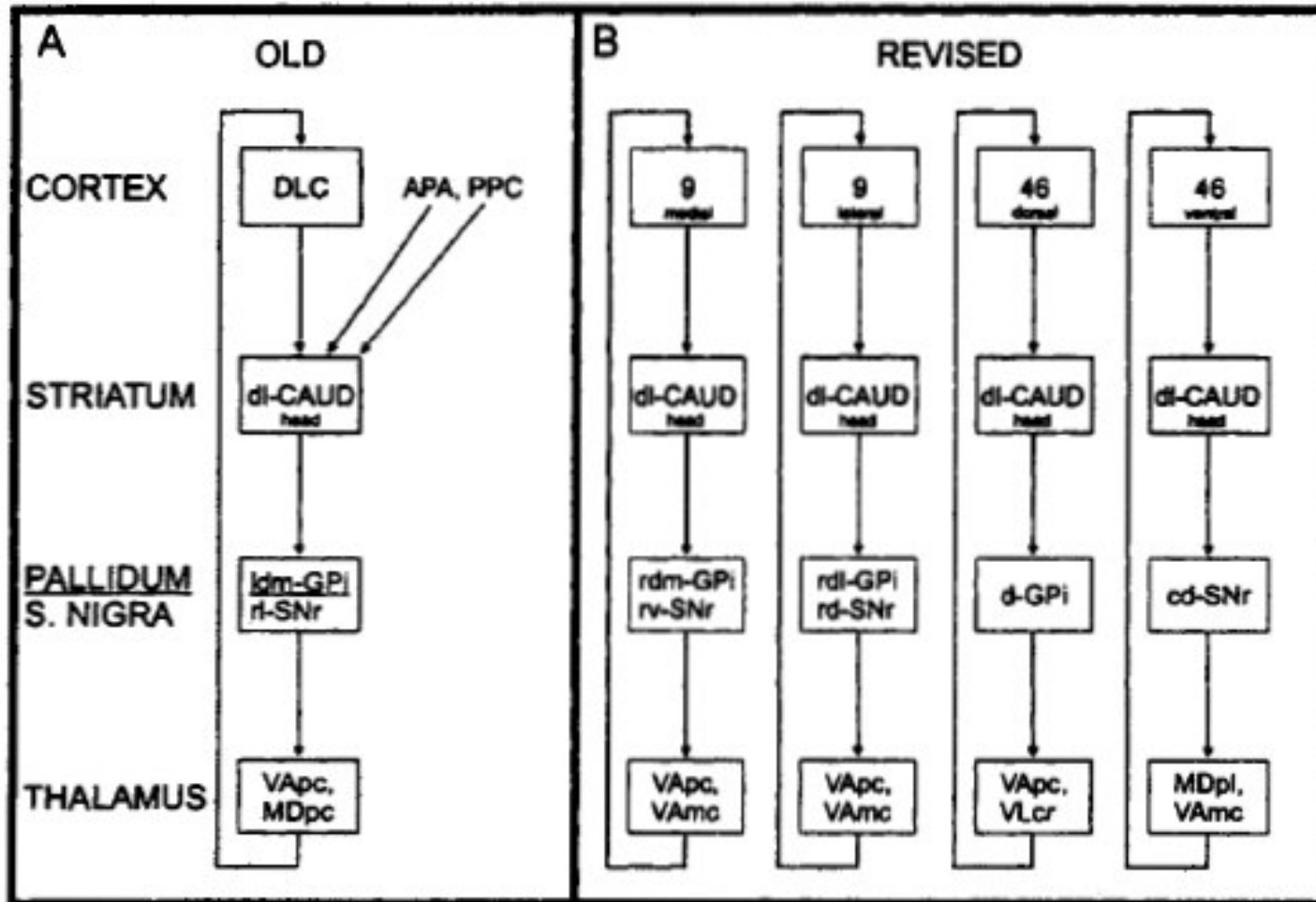

## 5. Prefrontal / Association Circuit 2

- Cortical projection is from superior, middle, and inferior temporal gyri, and anterior cingulate (ACA).
- Projection is to the head of the caudate (but different region than association circuit 1.)
- Pallidal and thalamic nuclei are similar to association circuit 1.
- Thalamocortical fibers project to the lateral orbitofrontal cortex (LOFC), part of the prefrontal lobe.
- Thought to be involved in the ability to change behavioral set.

# Lateral Orbitofrontal Circuit

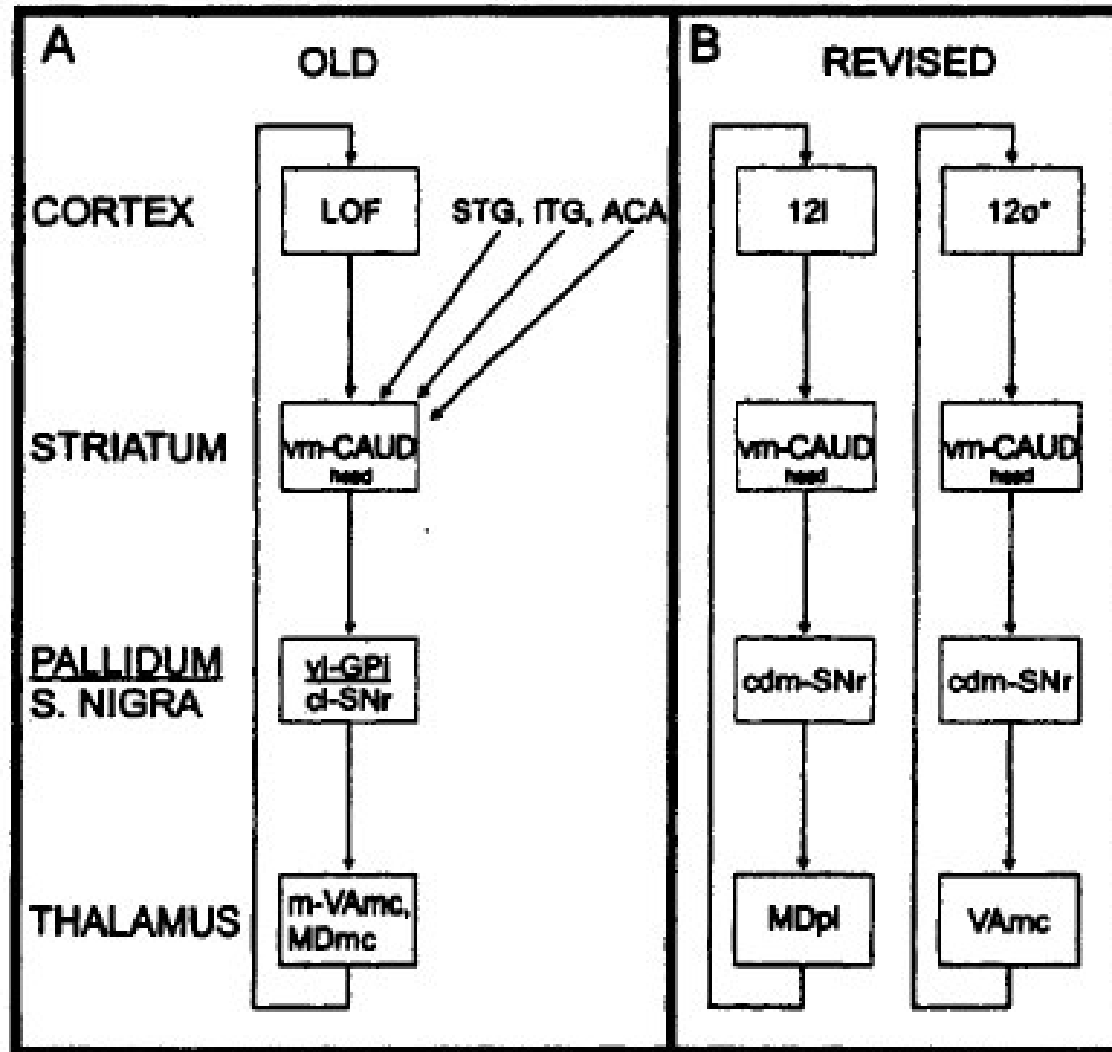

\*tentative

# Medial Orbitofrontal Circuit

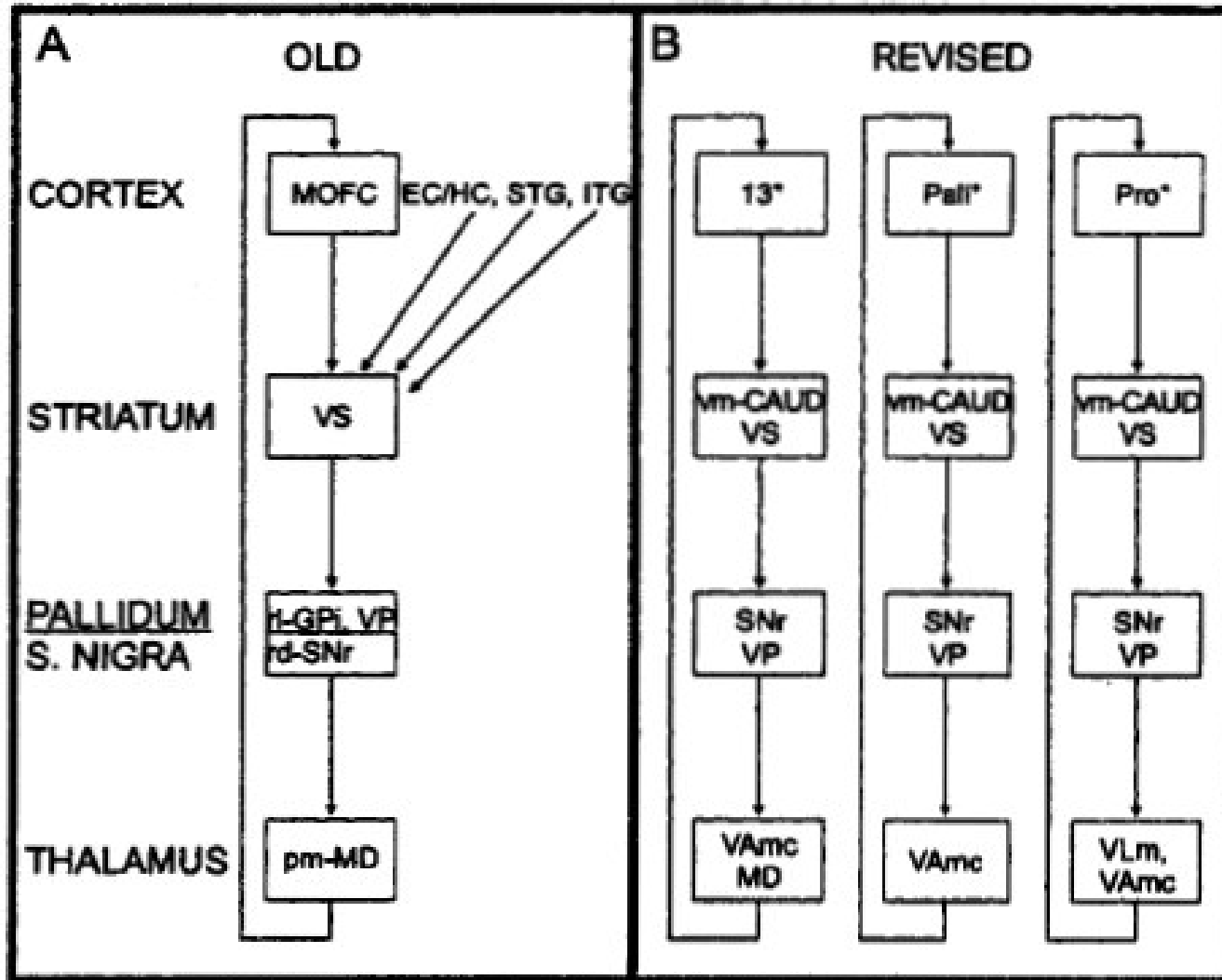

\*tentative

# Striosome and Matrix Projections

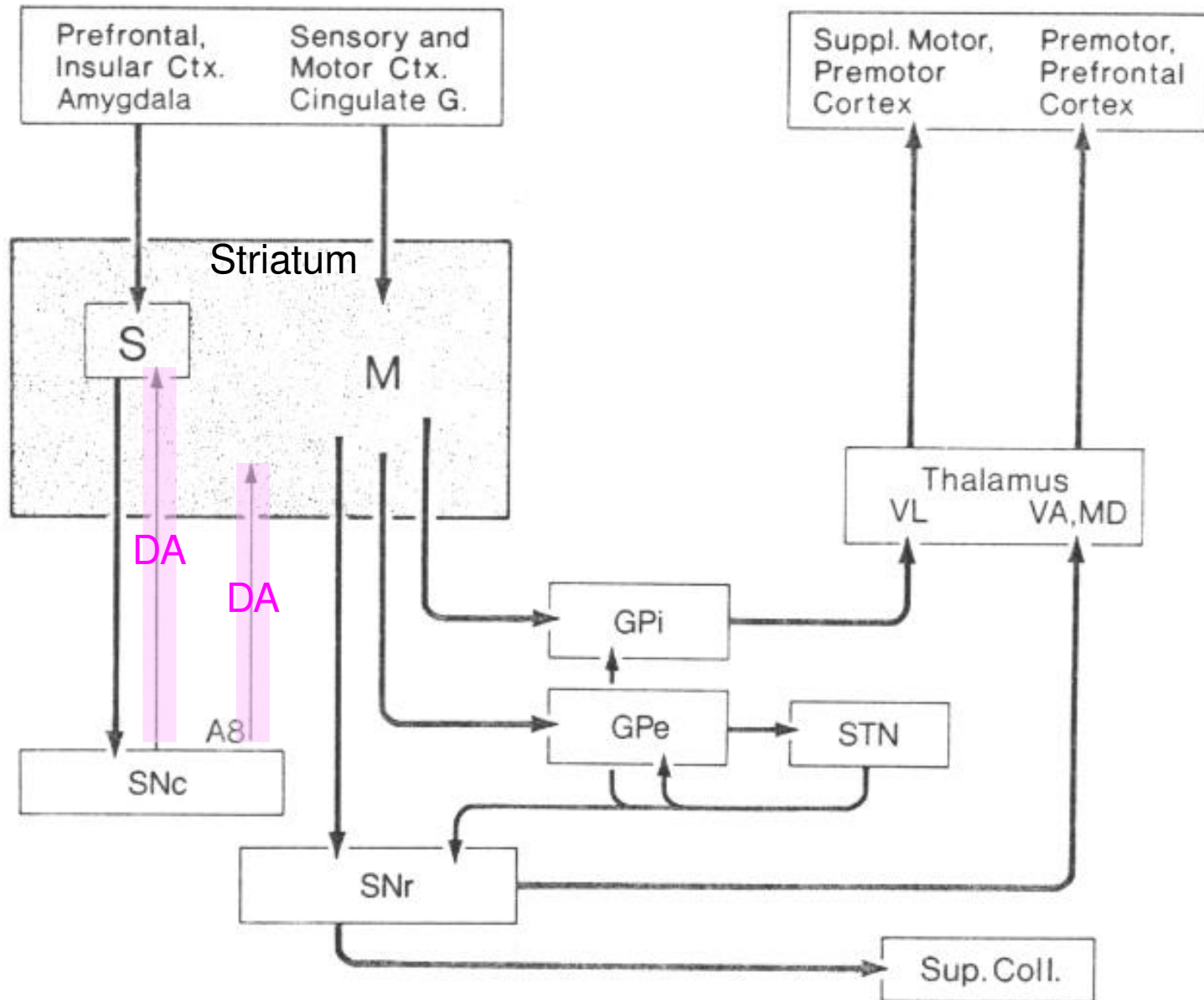

# Striatum and Behavior

- SMA, motor cortex, and putamen each contain separate populations of neurons sensitive to:
  - target location in space
  - limb trajectory variables
  - muscle pattern / movement force variables
- This suggests that the “motor channel” of basal ganglia may be composed of several distinct sub-channels.
- TANs (tonically active neurons) in striatum become sensitized to relevant stimuli in an operant conditioning task.
- Striatal neurons appear to code serial order of movements in chain grooming behavior in rats.

# Striatal Activity During Chain Grooming

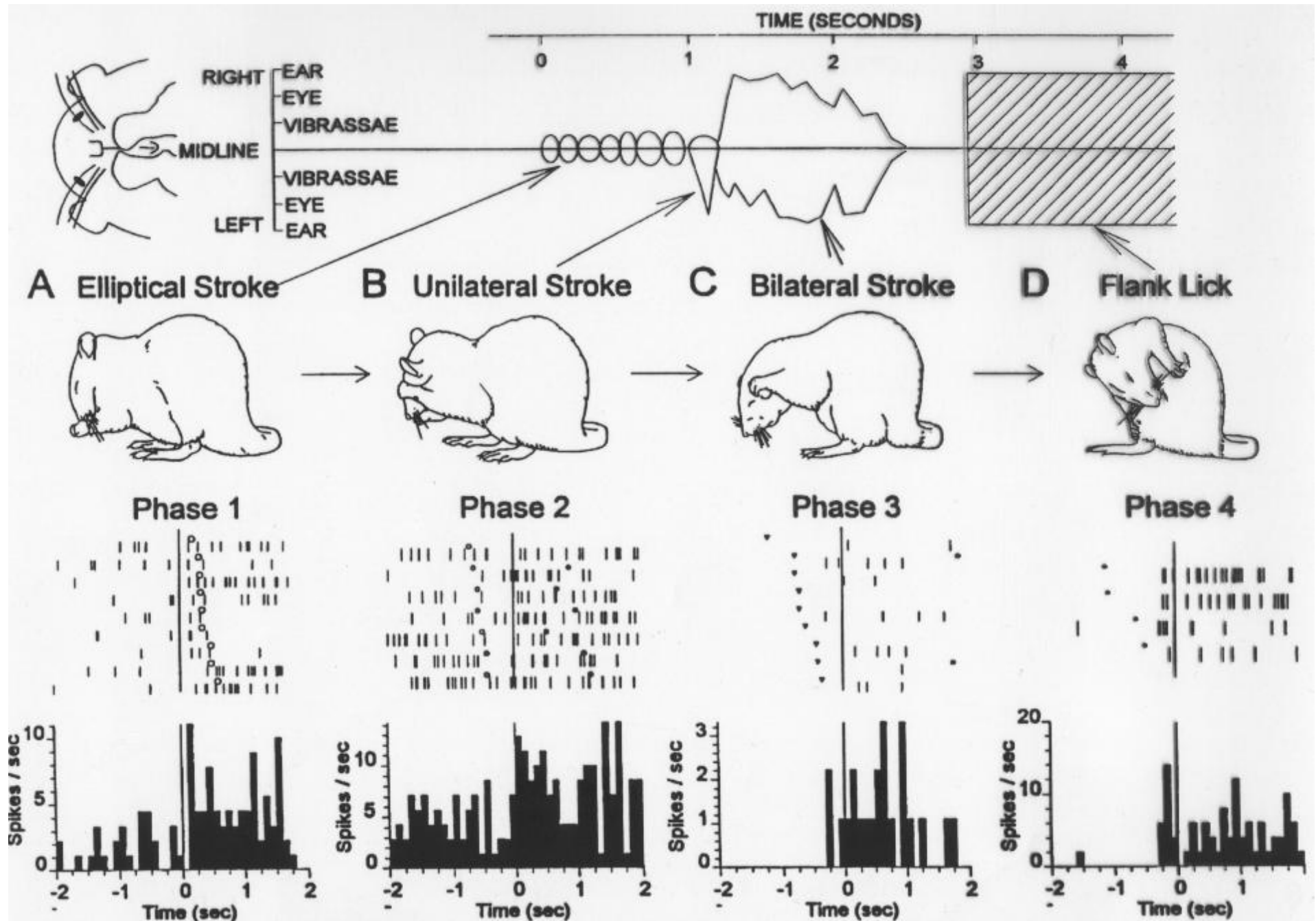

# Disease/Dysfunction of the Basal Ganglia

- Parkinson's disease
- Huntington's disease
- Tardive dyskinesia
- Ballism
- Obsessive-Compulsive Disorder

# Parkinson's Disease

- Cause: degeneration of nigrostriatal pathway (dopamine), raphe nucleus (serotonin), and locus ceruleus (norepinephrine) and motor nucleus of vagus.
- Third most common neurological disease; affects 500,000 Americans.
  - Michael J. Fox is a prominent sufferer and advocate for Parkinson's research.
- Partially hereditary: 15% of patients have a close relative with the disease.

# Parkinson's Disease (cont.)

- Symptoms:
  - tremor at 3-6 beats/second
  - cogwheel rigidity
  - akinesia (inability to initiate movements), bradykinesia (slow movement)
  - postural reflex impairment
- Treatments:
  - L-DOPA to increase dopamine levels. (L-DOPA is a dopamine precursor that crosses the blood-brain barrier.)
  - Anticholinergic agents.
  - Parkinsons treated with D2/D3 agonists causes cognitive changes; increased alcoholism, gambling addiction, inappropriate sexual behavior.
  - Surgery: pallidotomy (unilateral or bilateral), deep brain stimulation

# Treating Parkinsons with Deep Brain Stimulation

- Electrical stimulation of the subthalamic nucleus can dramatically reduce Parkinsonian tremor.
- “Pacemaker” implanted in chest with wires running to brain.

(see video)



# Huntington's Disease

- Cause: degeneration of intrastriatal and cortical cholinergic and GABA-ergic neurons. Result of an inherited anomaly in chromosome 4.
- Inhibitory interneurons in striatum use ACh. Loss of ACh disturbs the balance of the basal ganglia circuitry.
- About 10,000 cases in the US. Almost all cases in eastern US traced to two people from Suffolk, England who emigrated to Salem, Massachusetts in 1630.

# Huntington's Disease (cont.)

- Symptoms:
  - progressive disease, onset in 30s-50s but can occur in childhood
  - involuntary movements (chorea = “dance”)
  - behavioral or psychiatric disturbances
  - increasing dementia
  - death within 10-15 years
- Treatment:
  - No specific therapy.
  - Dopamine antagonists can help control the chorea.

# Ballism

- Cause: damage to subthalamic nucleus or globus pallidus, often due to stroke. Sometimes caused by hyperglycemia.
- Symptoms:
  - Most severe form of involuntary movement disorder known.
  - Tends to clear up slowly.
- Hemiballism: involuntary movements restricted to one side of the body.
- Treatment: neuroleptics (antipsychotics): phenothiazines or butyrophenones.

# Tardive Dyskinesia

- Cause: alteration in dopaminergic receptors causes hypersensitivity to dopamine.
- The problem results from long-term treatment with phenothiazines (like Thorazine) used to combat schizophrenia by blocking dopamine activity.
- Symptoms: involuntary movements, especially of the face and tongue, usually temporary.
- Treatment: discontinue use of phenothiazines.

# Obsessive-Compulsive Disorder

- Persistent upsetting thoughts; repeated ritualistic behaviors, e.g., hand washing.
- Affects 2.2 million American adults.
- Many treatment options:
  - psychotherapy
  - drugs
  - various surgeries: cingulotomy, capsulotomy, pallidotomy, ...
  - deep brain stimulation of STN, or ventral capsule/ventral striatum