

Neurophysiology for Computer Scientists

Computational Models of Neural Systems

David S. Touretzky
August, 2025

Outline

- Parts of a neuron
- Ionic basis of the resting potential
- Ionic basis of the action potential (spikes)
- Ligand-gated channels
- Synaptic transmission
- Second messengers
- Properties of dendritic trees

Neurons Come in Many Shapes

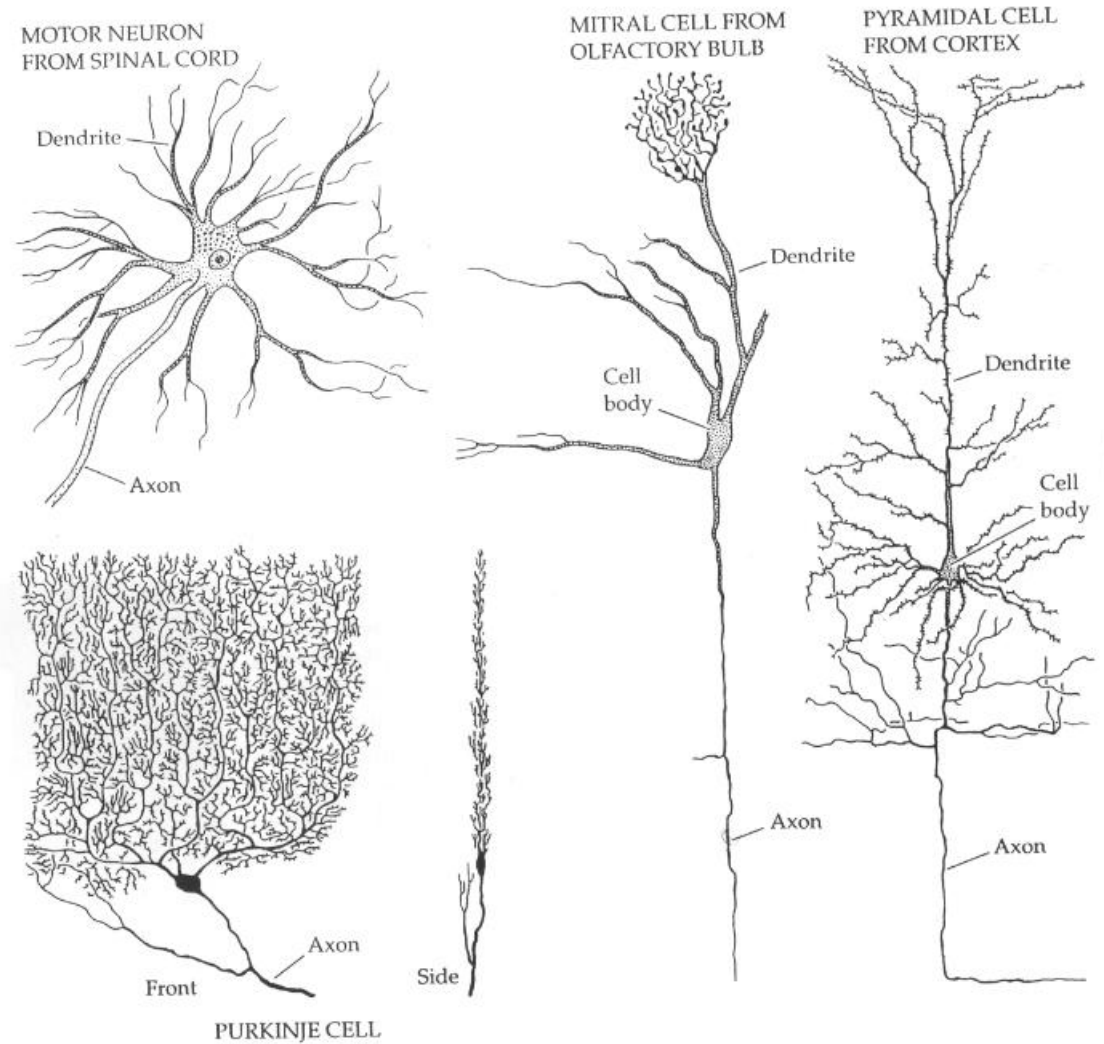

Nichols et al., From Neuron to Brain

Parts of a Neuron

1. Cell body (soma)

2. Dendrites

3. Axon

- Some cells lack dendrites, e.g., dorsal root ganglion cells in the spinal cord.
- Some cells lack axons, e.g., some types of amacrine cells in the retina.
- What is the difference between axon and dendrite?
 - Presence of spikes
 - Distribution of channel types
 - Pre- vs. post-synaptic structures

Structure of a Synapse

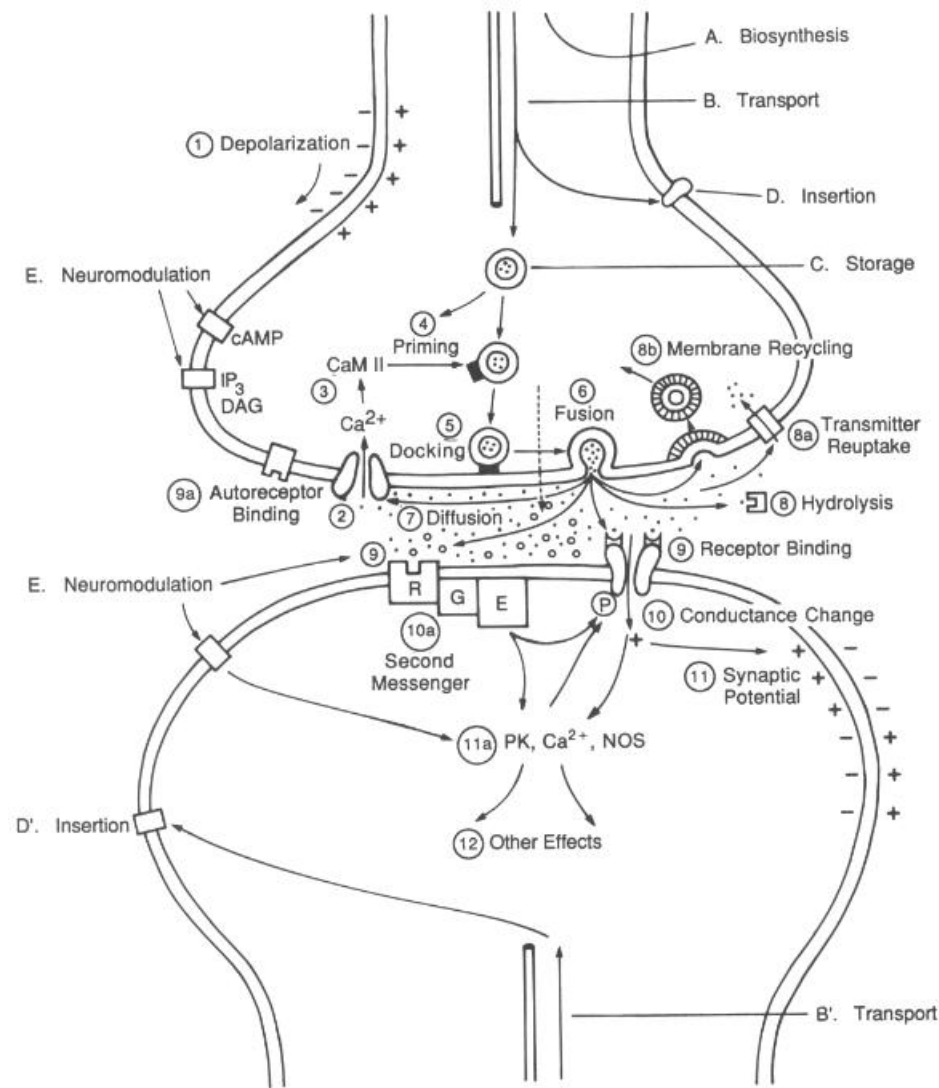

Gordon Shepherd, The Synaptic Organization of the Brain

Properties of Typical Cortical Neurons

1. Resting potential of -60 to -75 mV.
2. Sums inputs in a non-linear, temporal-dependent way.
3. Produces a spike (or burst of spikes) as output.
4. Only spikes if input is above threshold.
5. On the downward side of the spike, the cell can hyperpolarize: membrane potential drops as low as -90 mV.
6. Post-spike refractory period in which cells are much harder to excite.
7. Behavior can change in response to prolonged or repeated stimuli: “habituation”, “mode switching”, “fatigue”, etc.
8. Post-inhibitory rebound: if hyperpolarized by an inhibitory input, removing the input can result in a spike.

The Action Potential

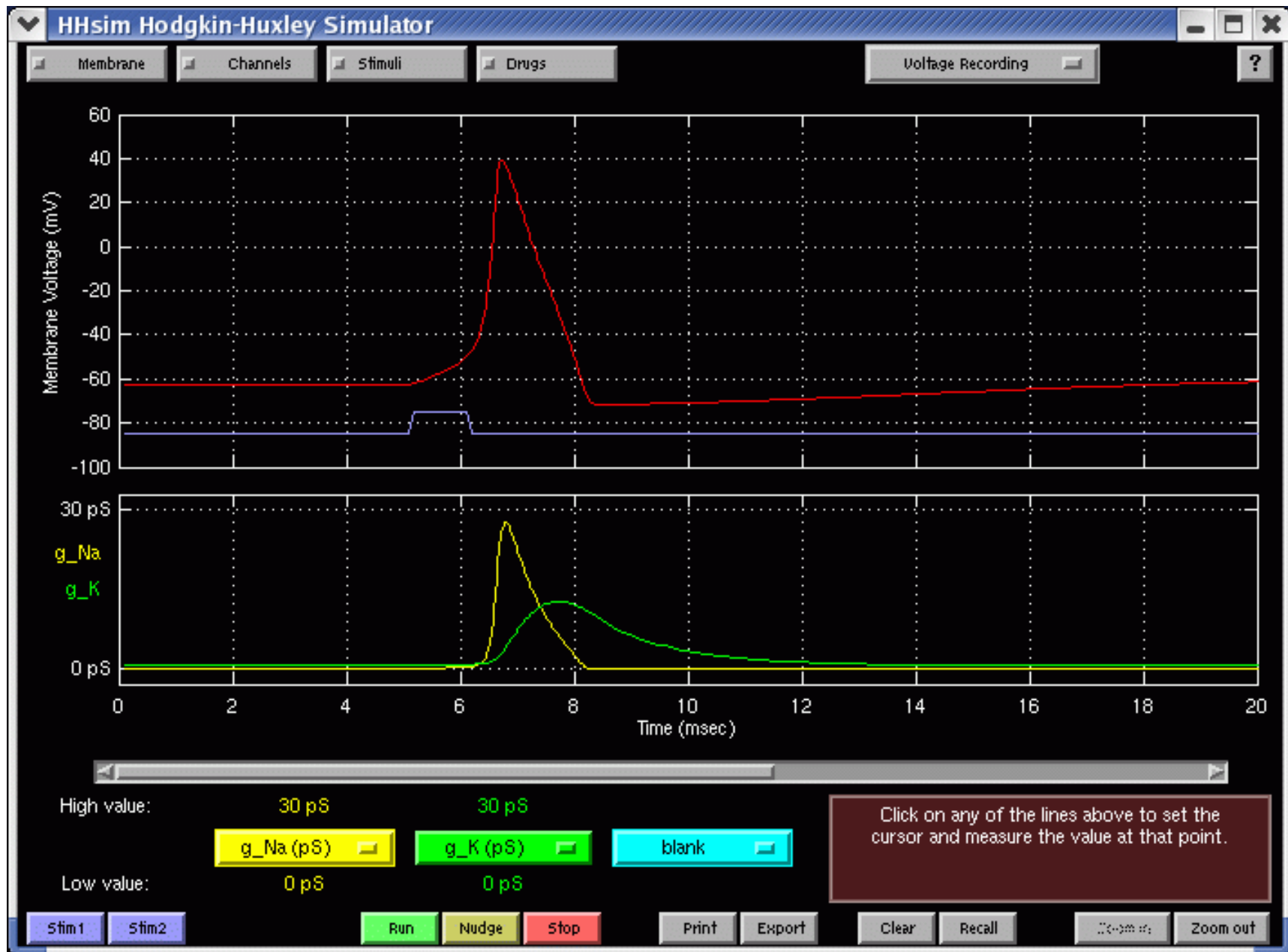

(Intra/Extra)-Cellular Ion Concentrations

Values are in mM, for typical CNS neurons:

	Extracellular	Intracellular
Na ⁺	150	30
K ⁺	3	140
Ca ²⁺	1.2	0.1
Cl ⁻	130	8
A ⁻	25	162

Positive and negative charges balance, inside & outside.

The cell membrane is a lipid bilayer: acts as an insulator.

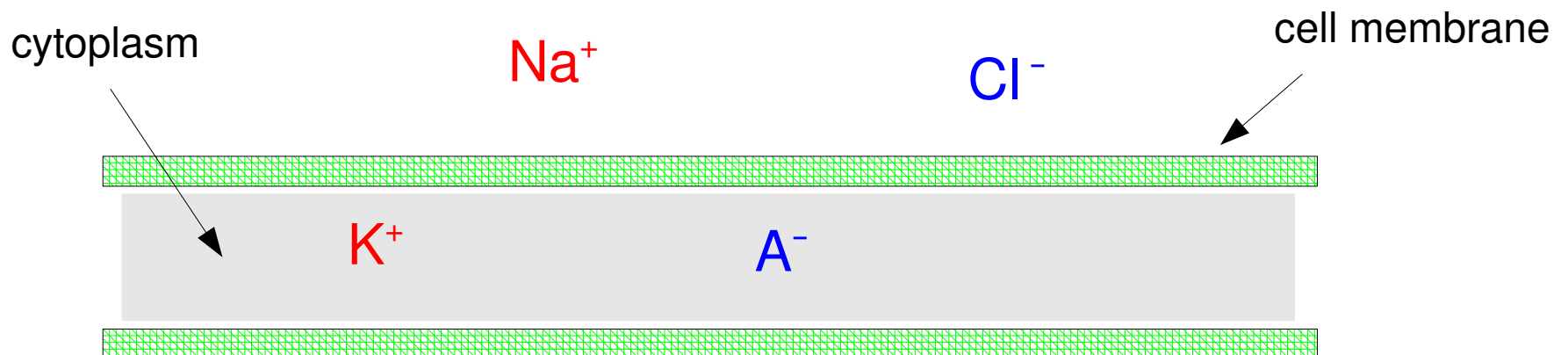

Passive Ion Channels

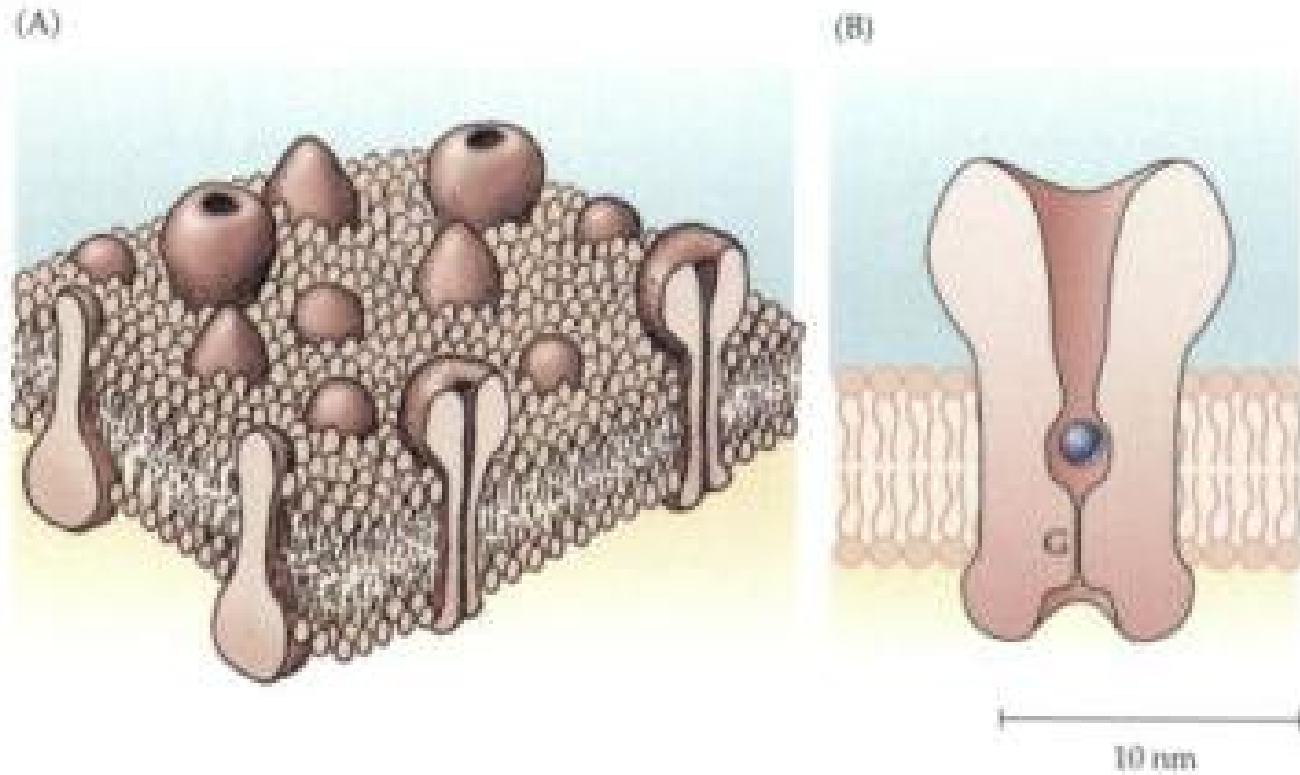

Nichols et al., From Neuron to Brain

Passive Ion Channels

- Membrane contains channels selectively permeable to K^+ . Concentration gradient favors K^+ flowing out of cell.

$$[K^+]_i = 140 \text{ mM} \quad [K^+]_o = 3 \text{ mM}$$

- K^+ ions continue to flow out until the cell's membrane potential V_m is -96 mV .
- Now the outward concentration gradient for K^+ is exactly counterbalanced by the inward electrical force.
- The cell's negative internal charge attracts positive ions, but only K^+ can pass through the channel.
- Positive charges cluster along the outer wall of the membrane; negative charges cluster along inner wall.

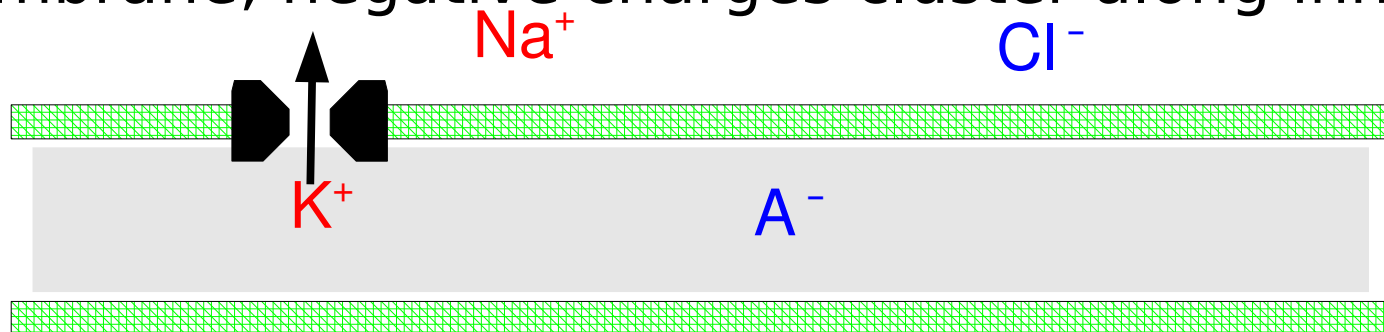

Reversal Potential for K⁺

- The Nernst Equation defines the equilibrium potential:

$$E_K = \frac{RT}{zF} \ln \frac{[K]_o}{[K]_i}$$

- R = thermodynamic gas constant;
T = temperature in °K;
z = valence (+1 for K⁺); F = Faraday's constant
- k = RT/zF = 25 mV at room temperature; E_K = -96 mV
- The cell membrane is only 50 Angstroms thick, so a -96 mV potential is like 192,000 V across a 1 cm membrane.

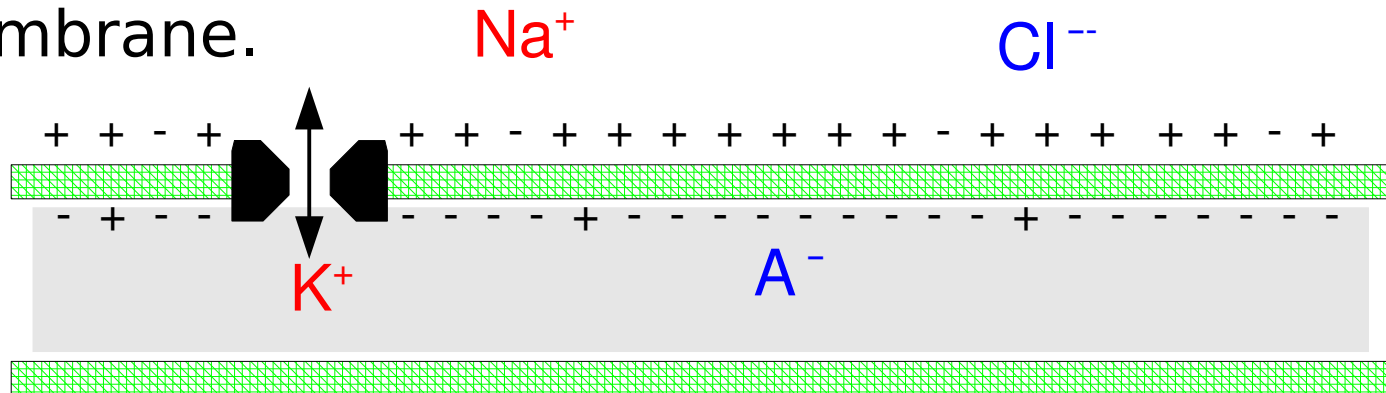

Manipulating the Reversal Potential

- By changing the extracellular concentration of K^+ , we can change the reversal potential.
- Example: we want E_K to go from -96 mV to -75 mV.
- This is exactly 3 times the RT/zF value of 25 mV.
- Calculate the K_o that will produce this reversal potential.

$$K_o = \exp\left(\frac{E_K}{RT/zF}\right) \cdot K_i = \exp(-3) \cdot 140 \text{ mM} = 7 \text{ mM}$$

- Solution: increase extracellular K^+ from 3 mM to 7 mM.

Two Other Ionic Currents

- Passive sodium channels allow inward sodium leakage.

$$E_{Na} = 25 \text{ mV} \cdot \ln \frac{[Na]_o}{[Na]_i} = 25 \text{ mV} \cdot \ln \frac{150 \text{ mM}}{30 \text{ mM}} = +40 \text{ mV}$$

- Passive chloride channels allow an inward Cl^- leakage.

$$E_{Cl} = -75 \text{ mV}.$$

- There is a simultaneous flow of K^+ , Na^+ , and Cl^- ions into and out of the cell.

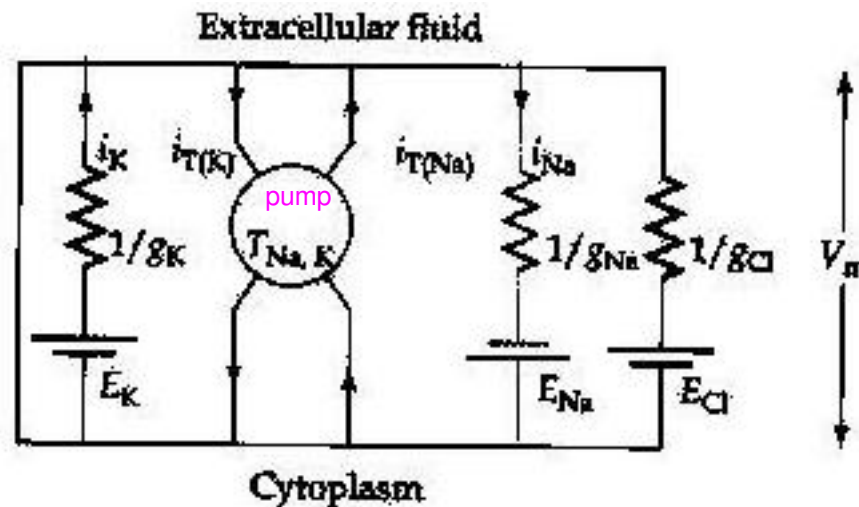

The Resting Potential

- The cell's membrane potential V_m is a weighted combination of the K^+ , Na^+ , and Cl^- reversal potentials.
- The different ion channels have different conductances: g_K , g_{Na} , and g_{Cl} .

- The Goldman-Hodgkin-Katz Equation:

$$V_m = \frac{E_K \times g_K + E_{Na} \times g_{Na} + E_{Cl} \times g_{Cl}}{g_K + g_{Na} + g_{Cl}}$$

- For typical cortical neurons the resting potential V_r is in the range of -60 to -75 mV.
- V_r is bounded from below by E_K and from above by E_{Na} .
- How could we increase g_K ?
 - Modify the channel structure
 - Add more channels to the membrane

The Sodium Pump

- *Why doesn't the cellular battery run down?*
- Electrogenic pumps maintain the cell's ionic balance.
- The sodium pump takes in 2 K^+ ions and expels 3 Na^+ ions on each cycle.
- The pump is powered by ATP (adenosine triphosphate).

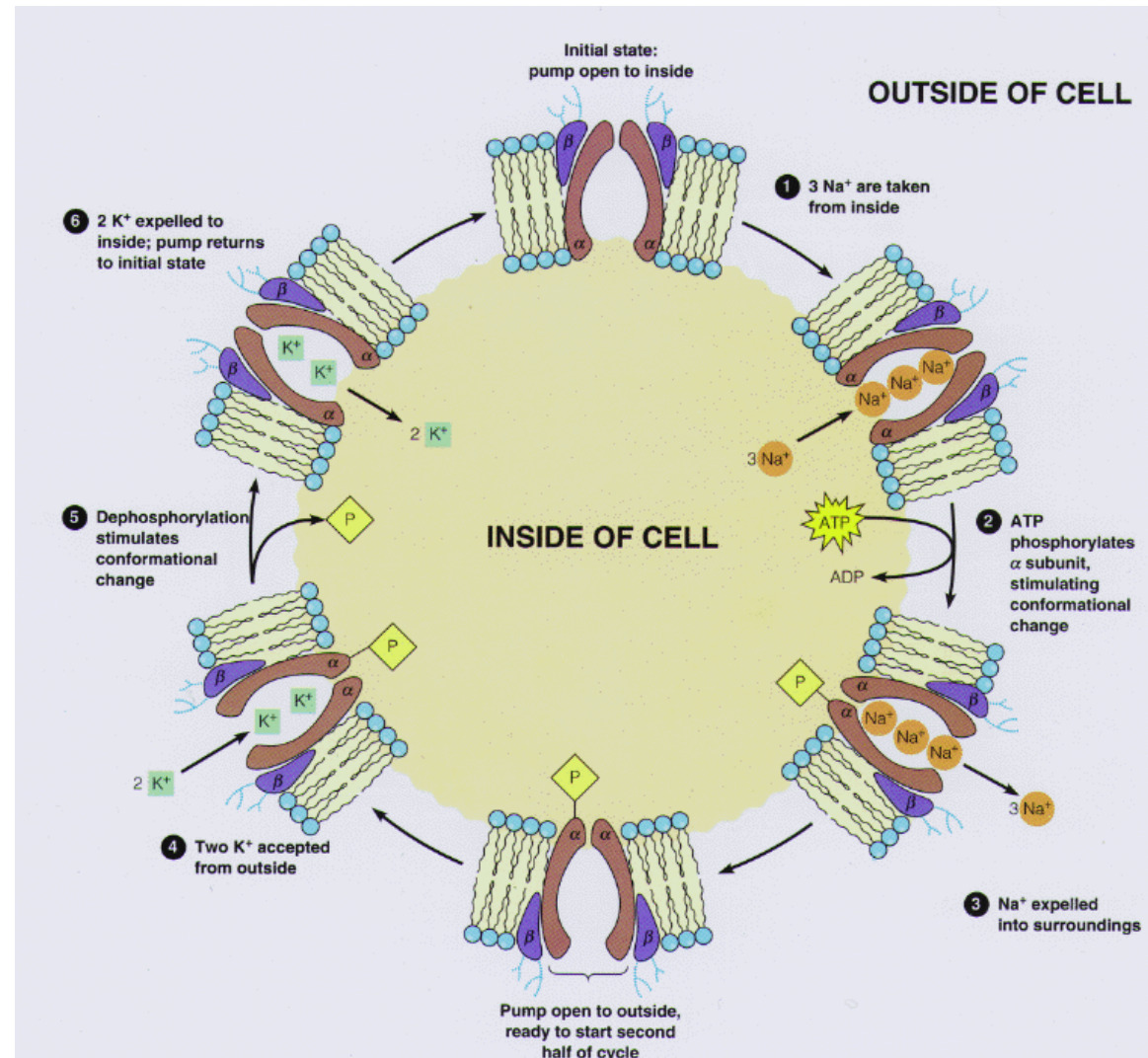

From Mathews and van Holde: *Biochemistry 2/e*. The Benjamin/Cummings Publishing Co., Inc.

The Action Potential

Suppose V_m rises above -55 mV (the spike threshold).

1. Voltage-gated Na^+ channels begin to open.
2. This increases g_{Na} , so more Na^+ ions enter the cell. The membrane becomes further depolarized, causing more channels to open and even more Na^+ ions to enter the cell.
3. Sodium channels become refractory and incoming Na^+ current stops.

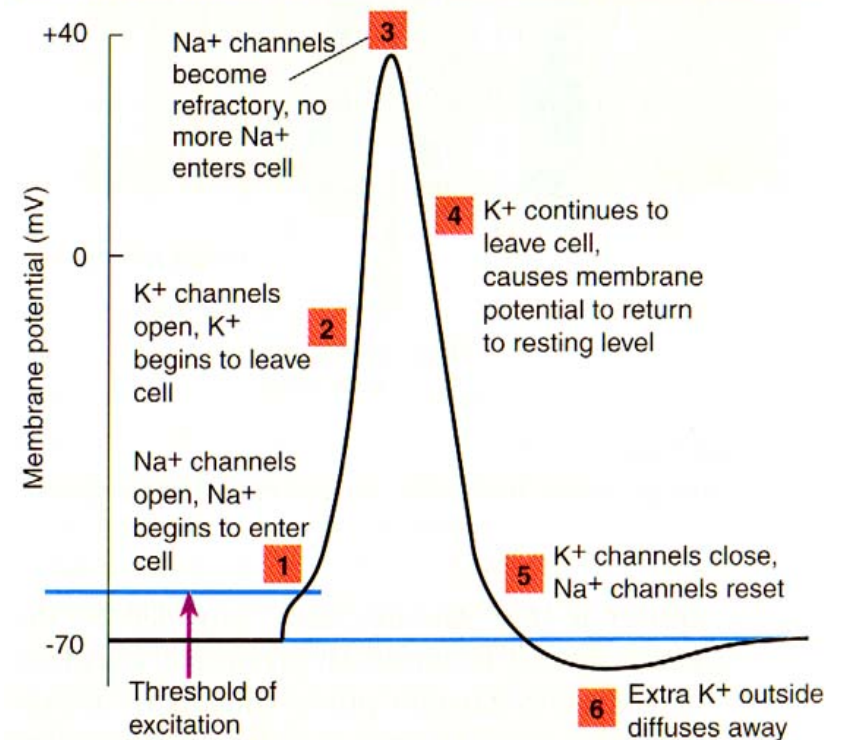
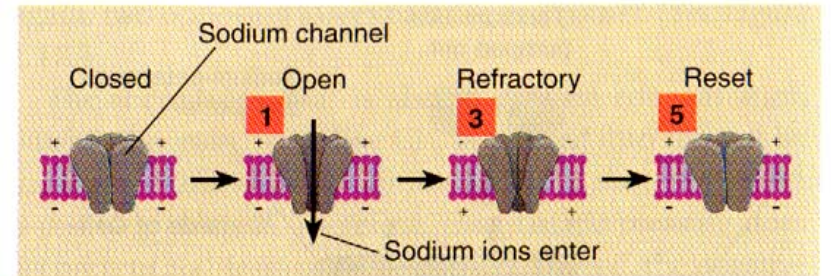

The Action Potential (cont.)

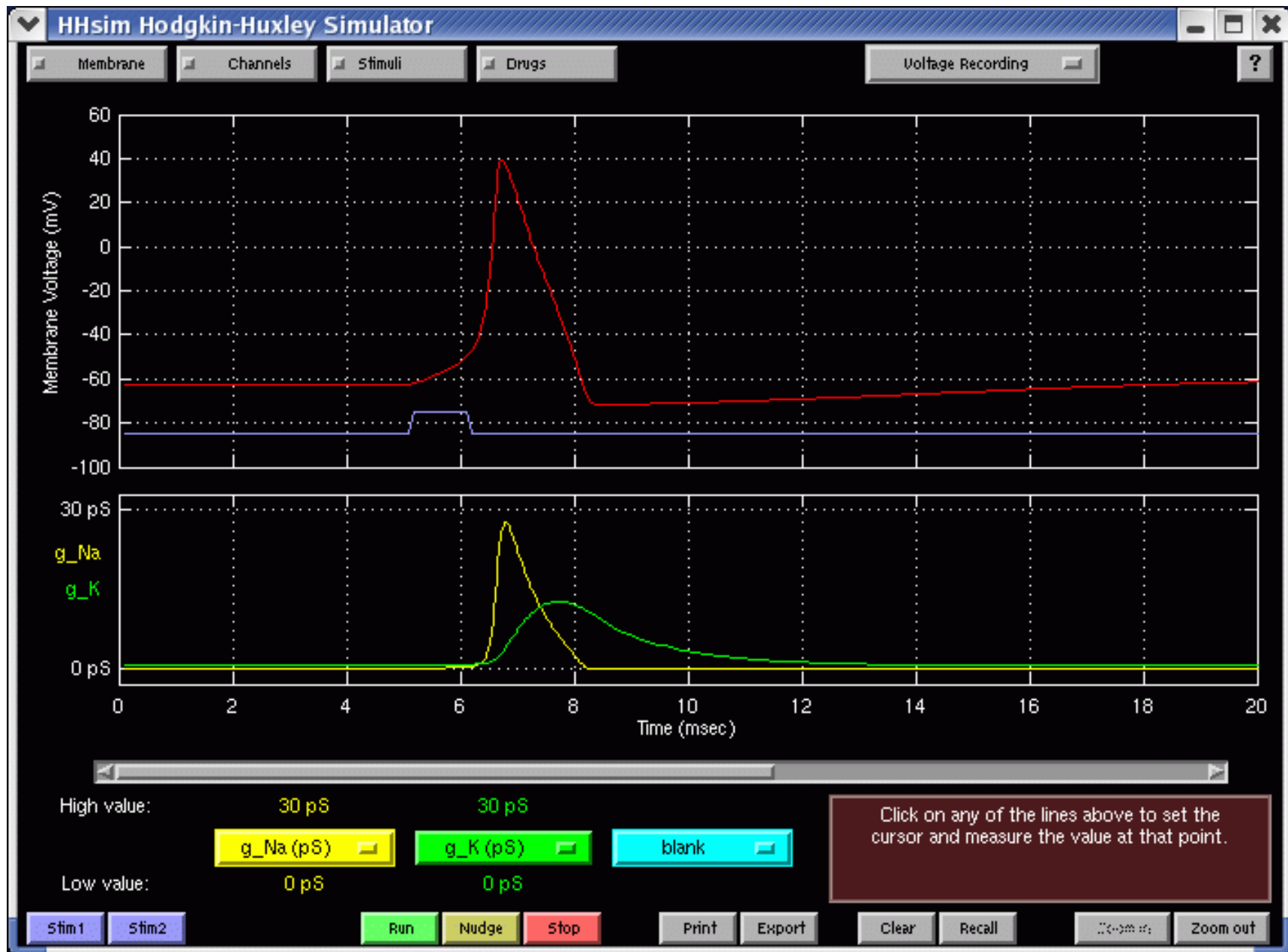

The Action Potential (cont.)

- Why are spikes sharp?
 2. As V_m rises, voltage-gated K^+ channels begin to open.
 3. Rise in g_k is slow at first, then speeds up, so K^+ ions leave the cell at a high rate.
 4. The membrane potential drops.
 5. Since g_k is higher than normal, V_m can even temporarily drop to below V_r (but not below E_K).
(This is the cause of after-hyperpolarization.)
 6. As V_m drops, the voltage-gated K^+ channels gradually close, and the passive current flows bring the cell back to V_r .

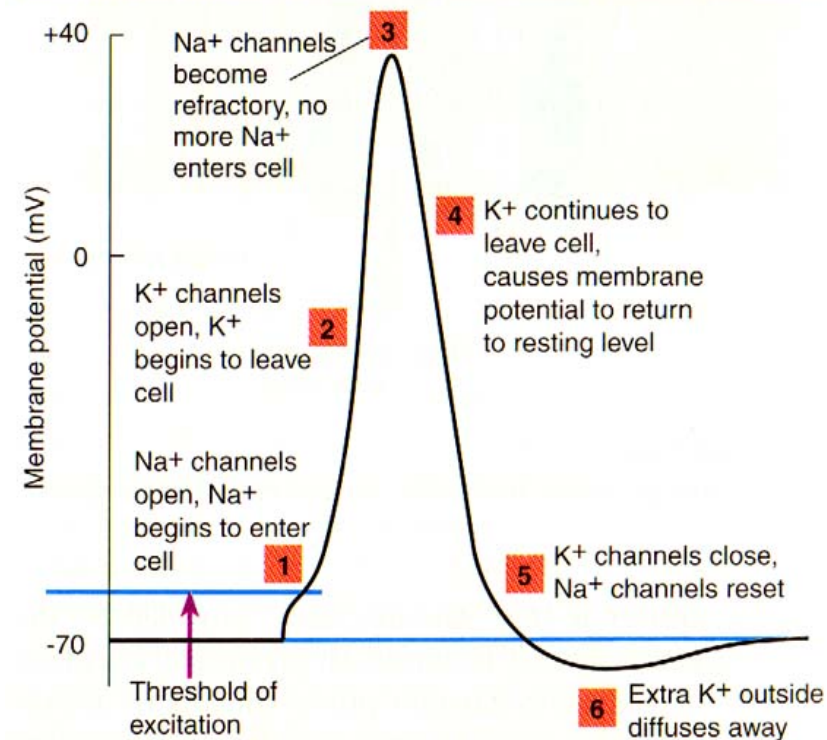
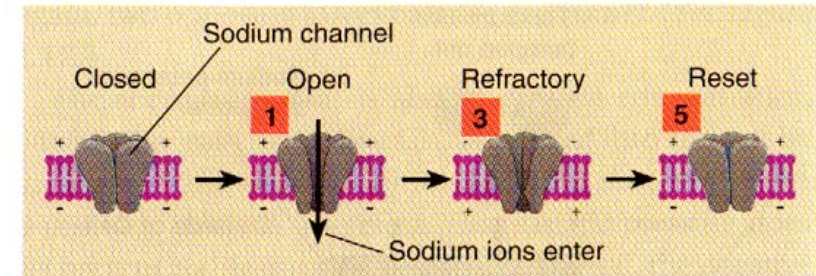

Sodium Channel States

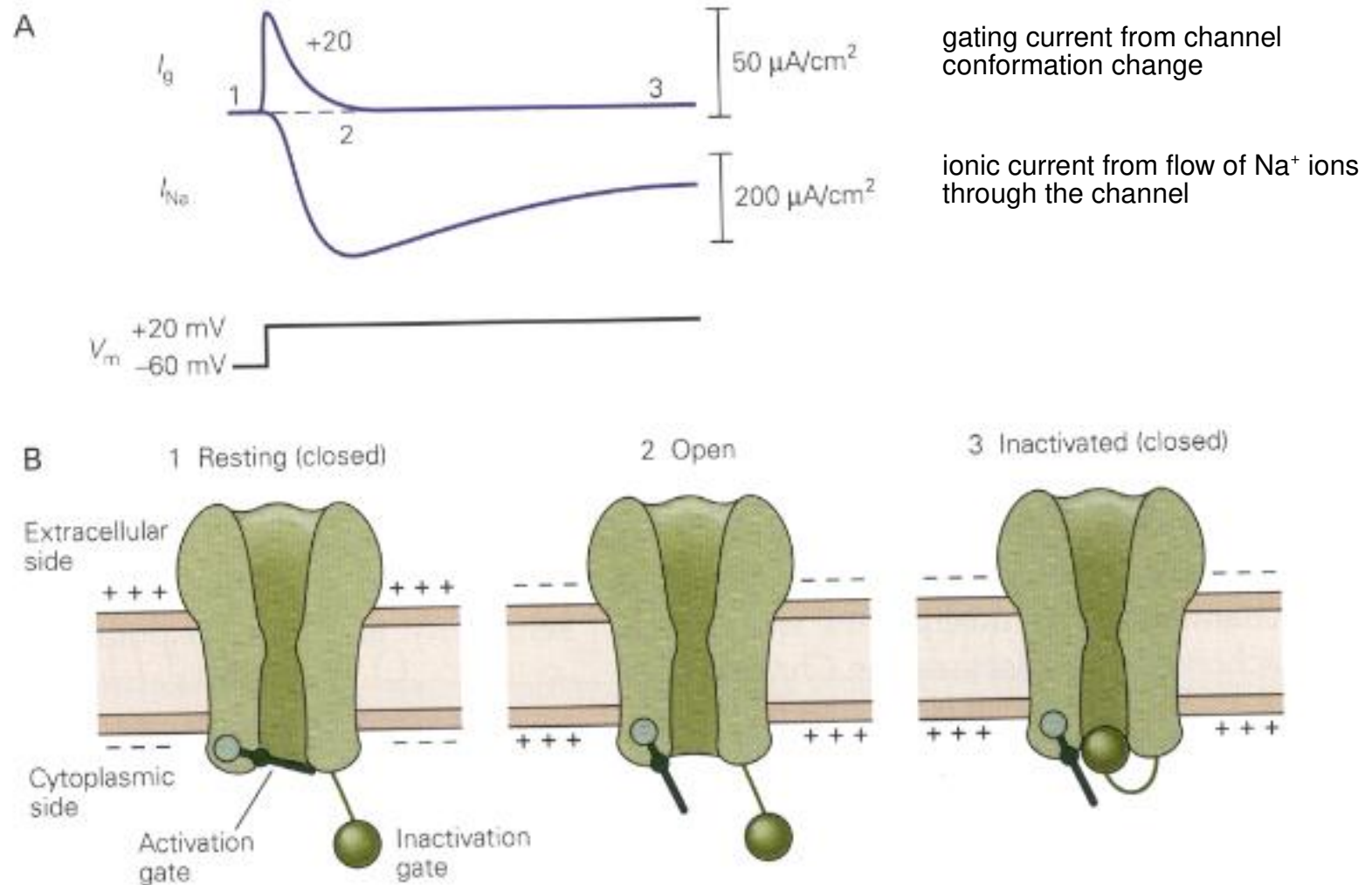

gating current from channel conformation change

ionic current from flow of Na^+ ions through the channel

Channel Behavior

- The sodium channel has several states: open, closed (with several substates), and inactive.
- Each state corresponds to a movement of charge within the channel, causing a conformational change in the protein.
- A series of 3-4 conformational changes bring the channel from the closed to the open state.
- Once the channel is open, the inactivation gate can close, blocking ion flow again.
- Once the channel is open, the inactivation gate can close, blocking ion flow again.

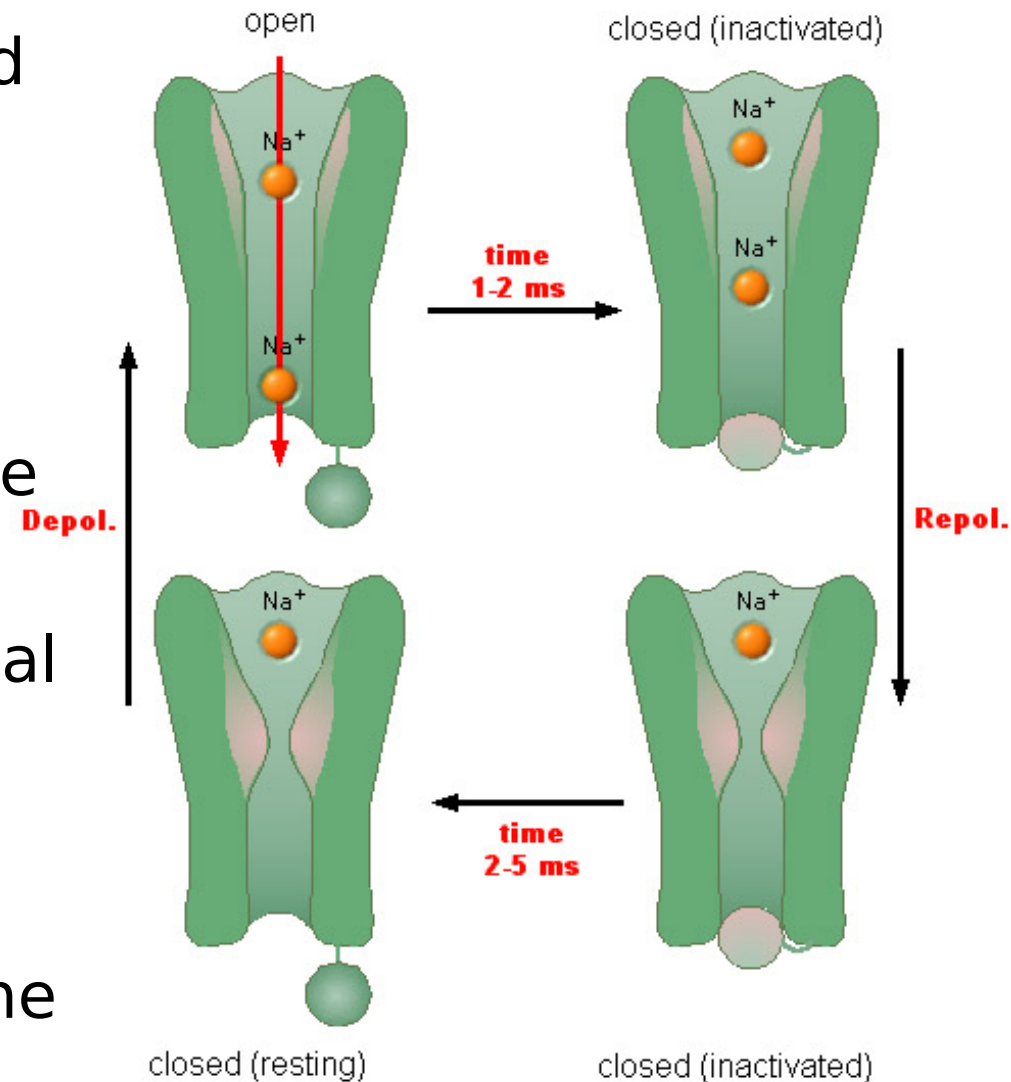

Channel Behavior

- State changes are stochastic, influenced by V_m .

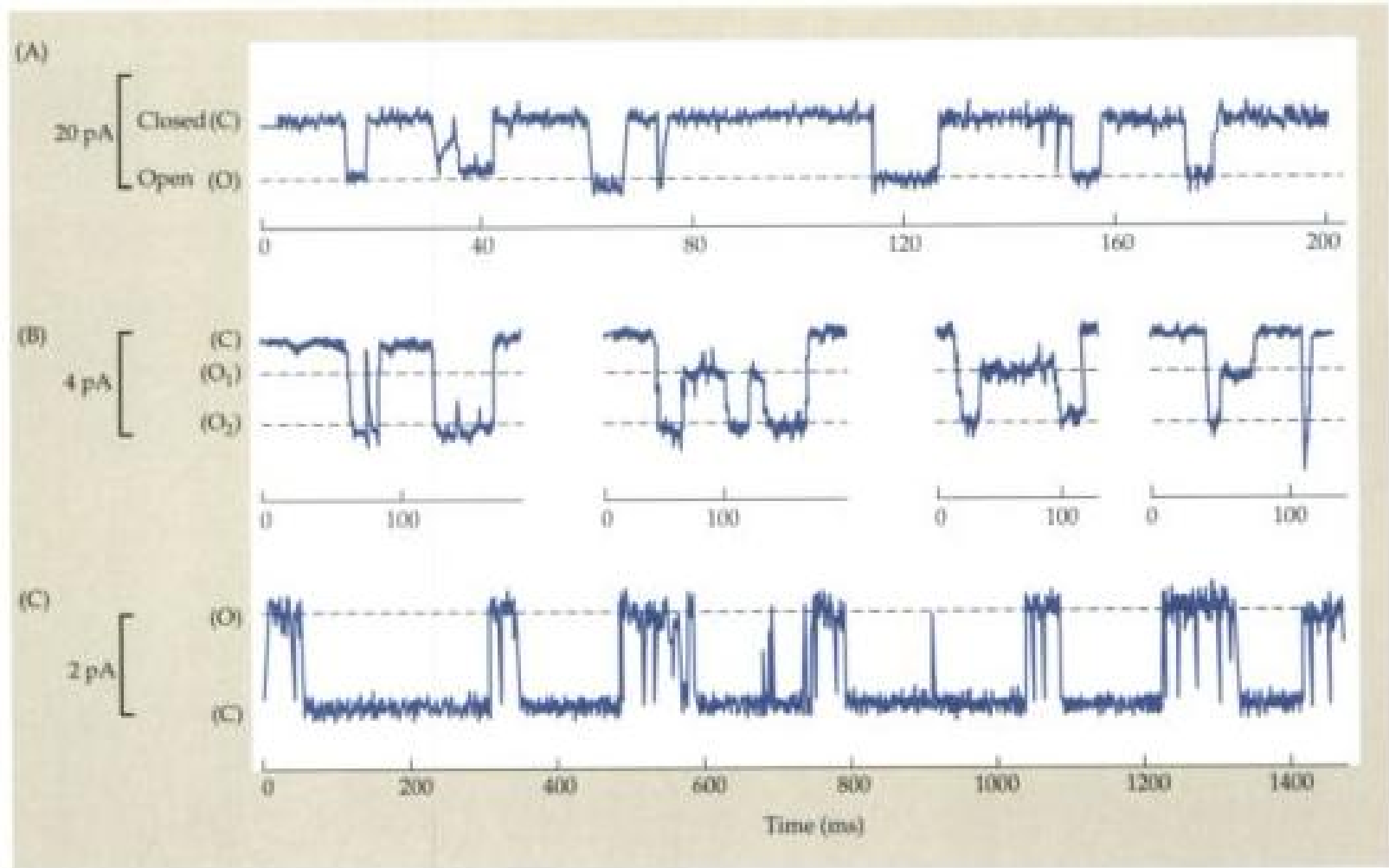

Post-Inhibitory Rebound

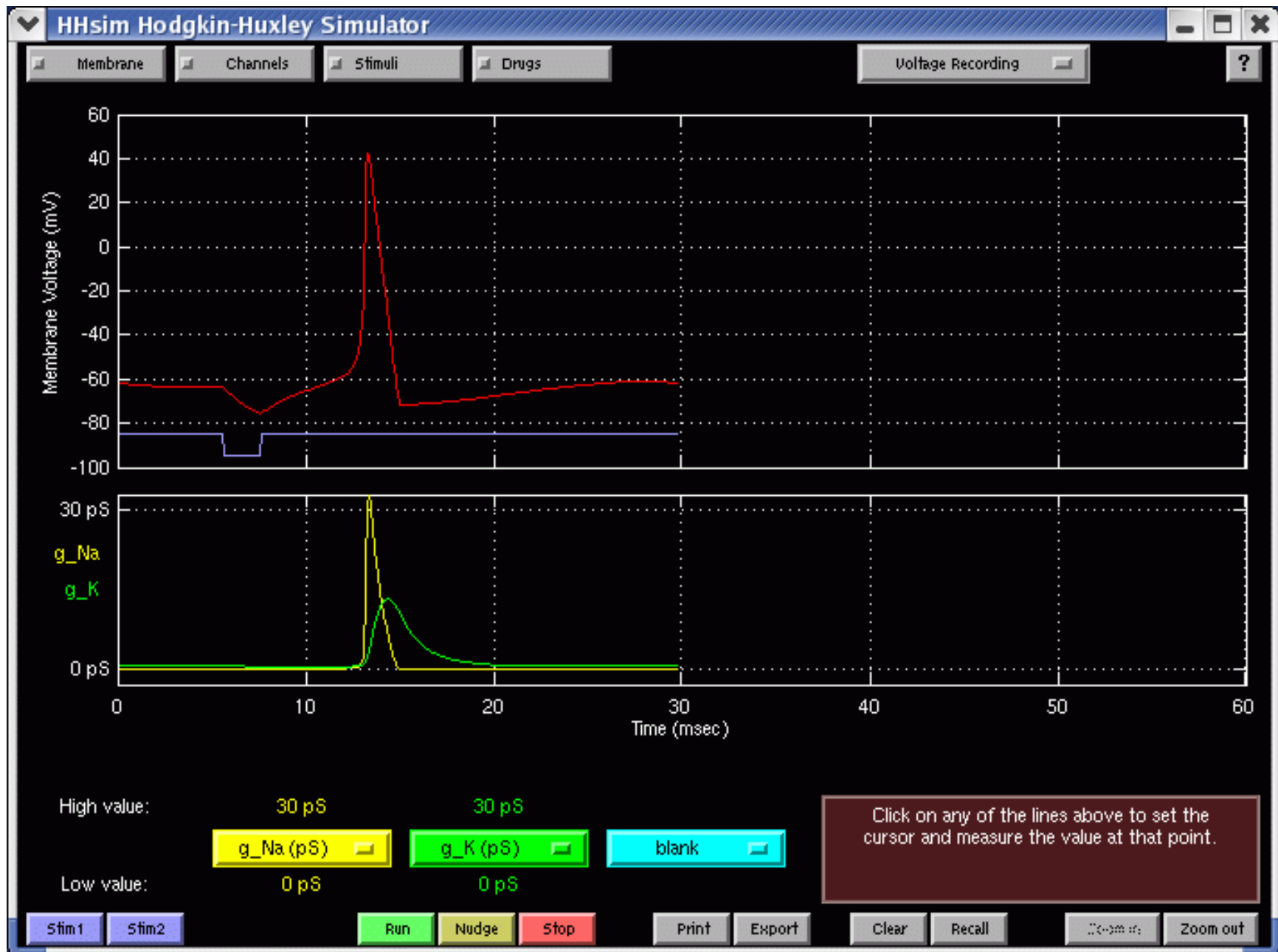

The Hodgkin-Huxley Model

- The voltage-gated sodium channel has 3 activation subunits (m) and one inactivation subunit (h).
- All subunits must be in the “open” state for Na^+ ions to flow.
- Conductance is proportional to m^3h .

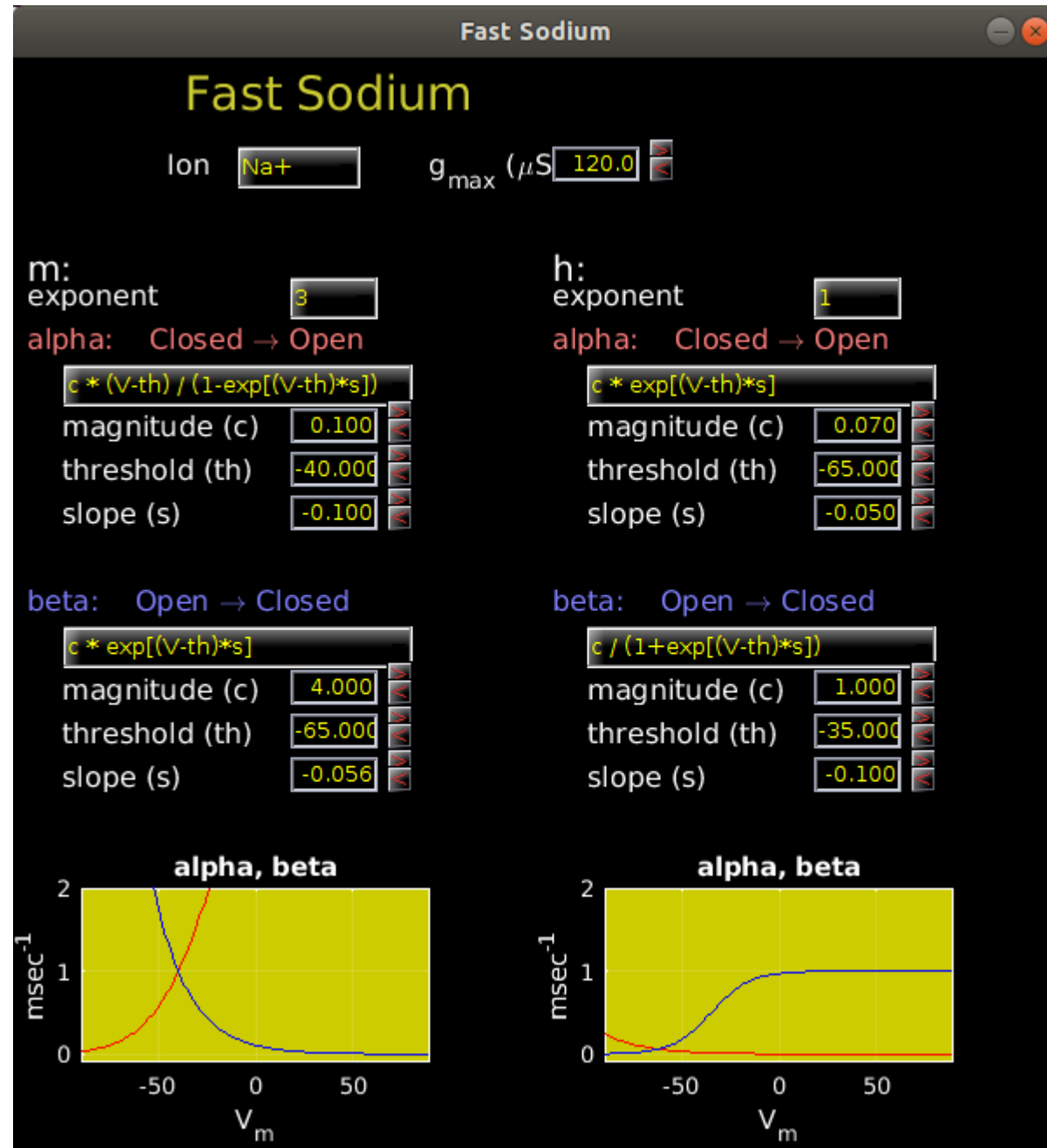

The Hodgkin-Huxley Model

- The voltage-gated potassium channel as 4 activation subunits (n).
- All subunits must be in the “open” state for K^+ ions to flow.
- Conductance is proportional to n^4 .

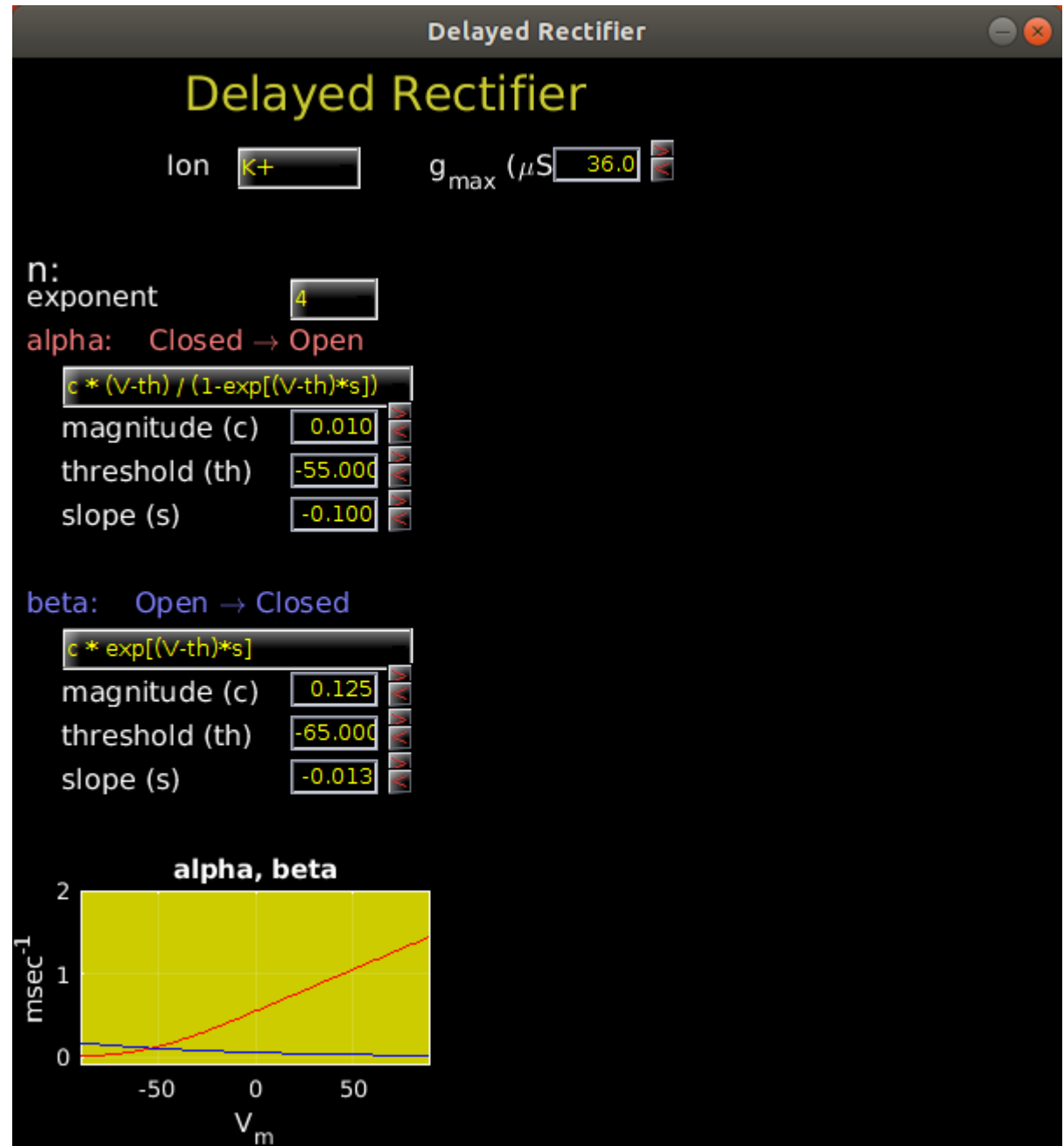

Hodgkin-Huxley Spiking

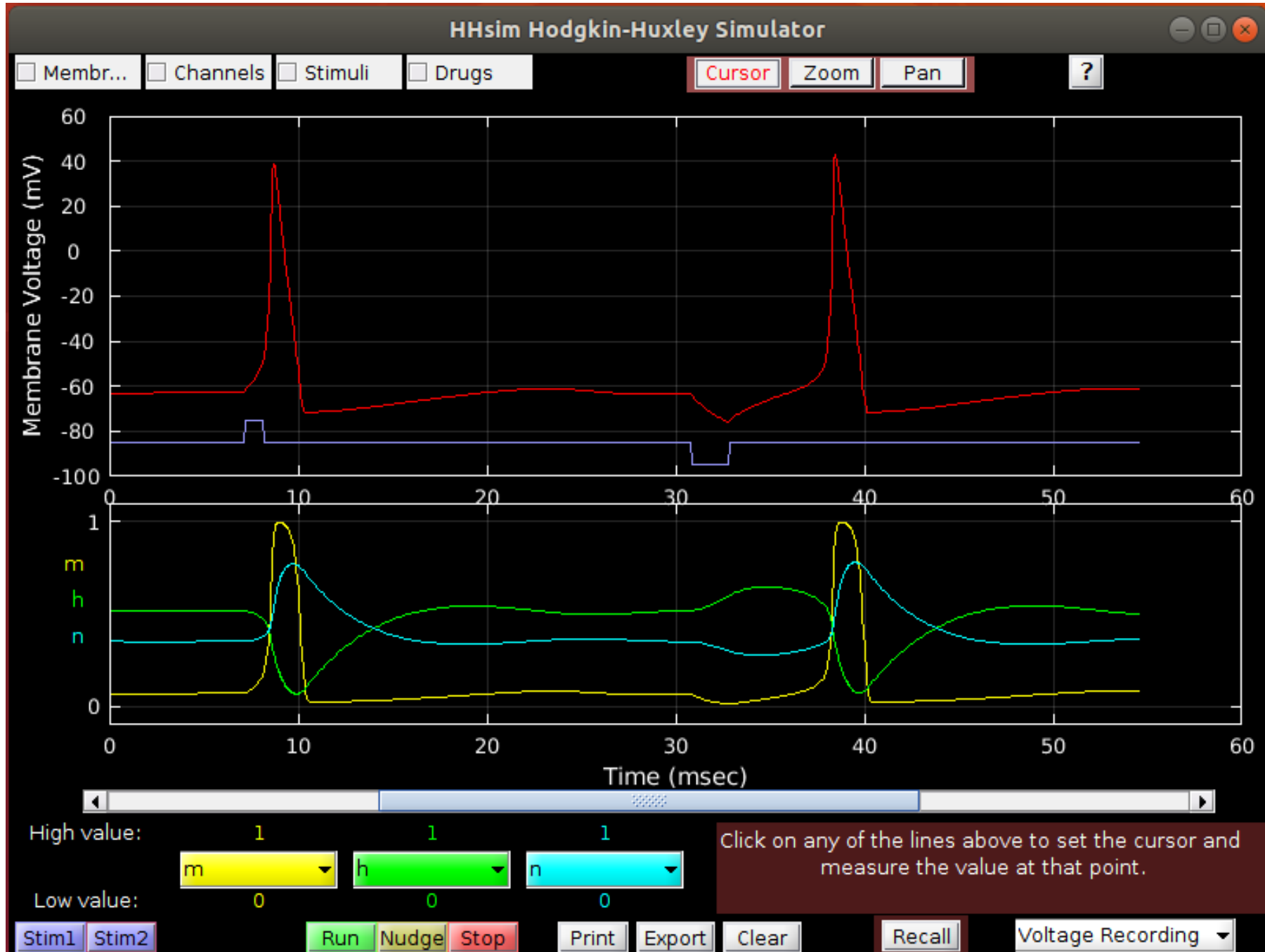

Types of Ionic Currents

- There are more than a dozen voltage-gated ion currents.
- Each has a different time course of activation and inactivation.
- $I_{Na,t}$ is the fast, transient sodium current responsible for action potentials.
- I_K is one of several currents responsible for repolarization after an action potential.
- I_{AHP} is a slow potassium current triggered by Ca^{2+} influx, responsible for adaptation of the action potential with repeated firing.
- Complex spike patterns in some cells are thought to involve as many as 10 distinct ion currents.

Parabolic Bursting

- Parabolic bursting in rat sciatic nerve:

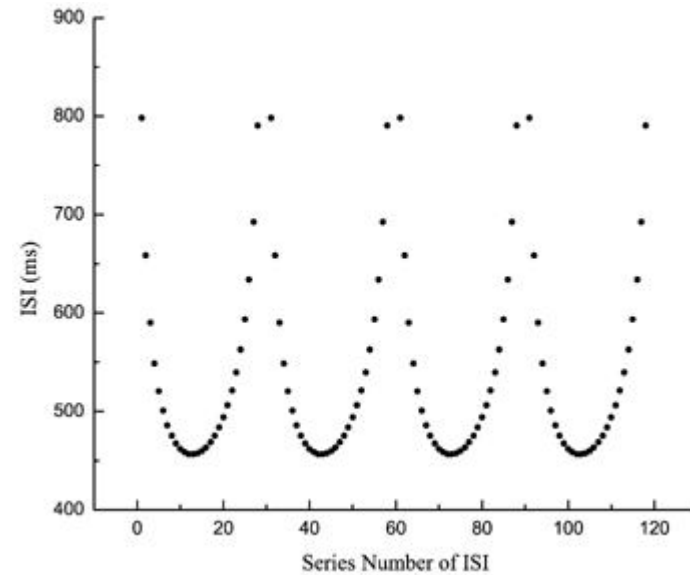
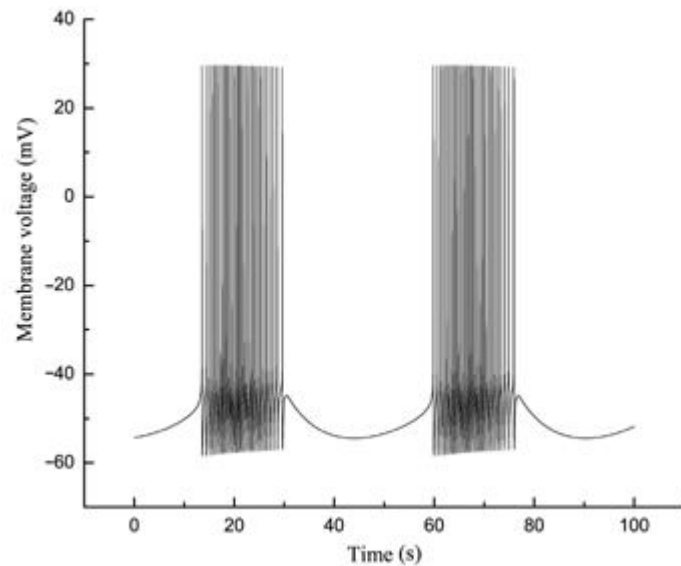

Yong et al. (2003) Parabolic bursting induced by veratridine in rat injured sciatic nerves.

- Aplysia R15 parabolic cell: parabolic bursting involves at least 7 different channel types.

Propagation of the Action Potential

- A region of membrane is depolarized due to Na^+ channels opening.
- The depolarization spreads to nearby patches of membrane as ions flow into the cell.
- Channels in these new patches then begin to open.
- The “spike” is a traveling wave that begins at the soma.
- It can travel in either direction along an axon: prodromic or antidromic.
- Normally it only travels forward.
- Why doesn't it reflect backward when it gets to the end of the axon?

Propagation of the Action Potential

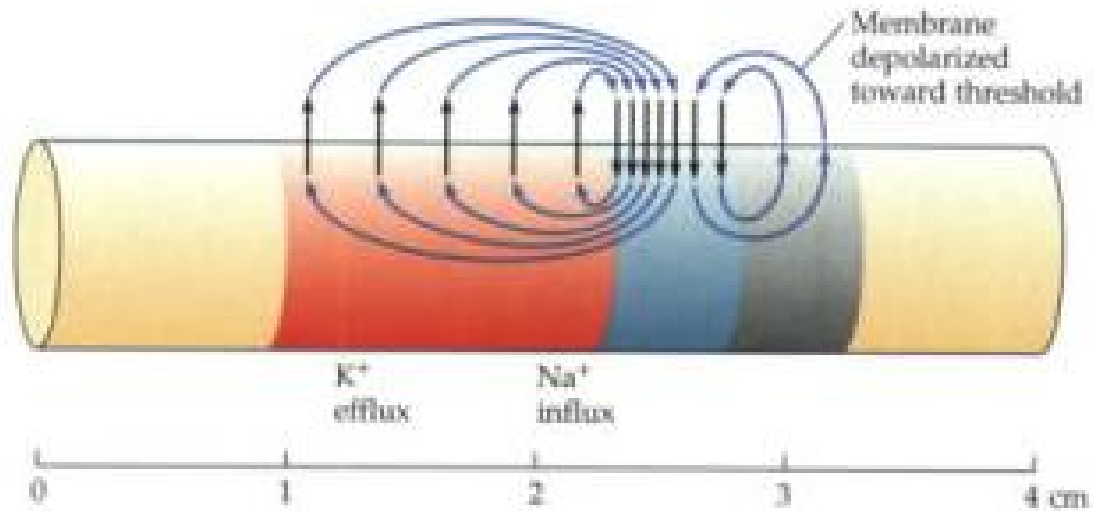
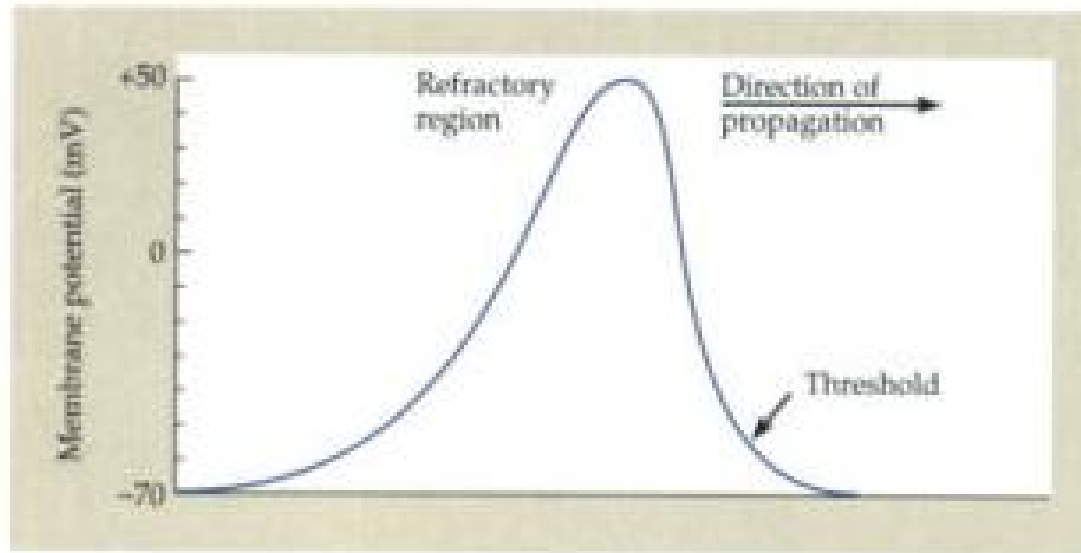

What About Calcium?

- Ca^{2+} is present in only small amounts in the cell: 0.1 mM compared to 140mM for K^+ .
- Extracellular concentration is also small: 1.2 mM.
- Thus, Ca^{2+} doesn't contribute significantly to the resting potential or the normal (sodium) axonal spike.
- It can, however, contribute to some types of spikes.
- Ca^{2+} is crucial for triggering many important operations in neurons, such as transmitter release.
- Thus, when a little bit of extra calcium does enter the cell, it has a big effect.
- If a cell is overstimulated, too much Ca^{2+} can enter, which could poison it.
 - This is why epileptic seizures can cause brain damage.

Transmitter Release

- The *synaptic bouton* contains voltage-sensitive Ca^{2+} channels that open when the spike depolarizes the membrane.
- Calcium enters the bouton and triggers metabolic reactions that result in transmitter release.
- A vesicle fuses with the membrane surface and dumps its transmitter into the synaptic cleft.
- This is a probabilistic process. A single spike may only result in release of a packet of transmitter 10% of the time.
- Some cells can release more than one type of transmitter. This was only discovered recently.

Transmitter Release (cont.)

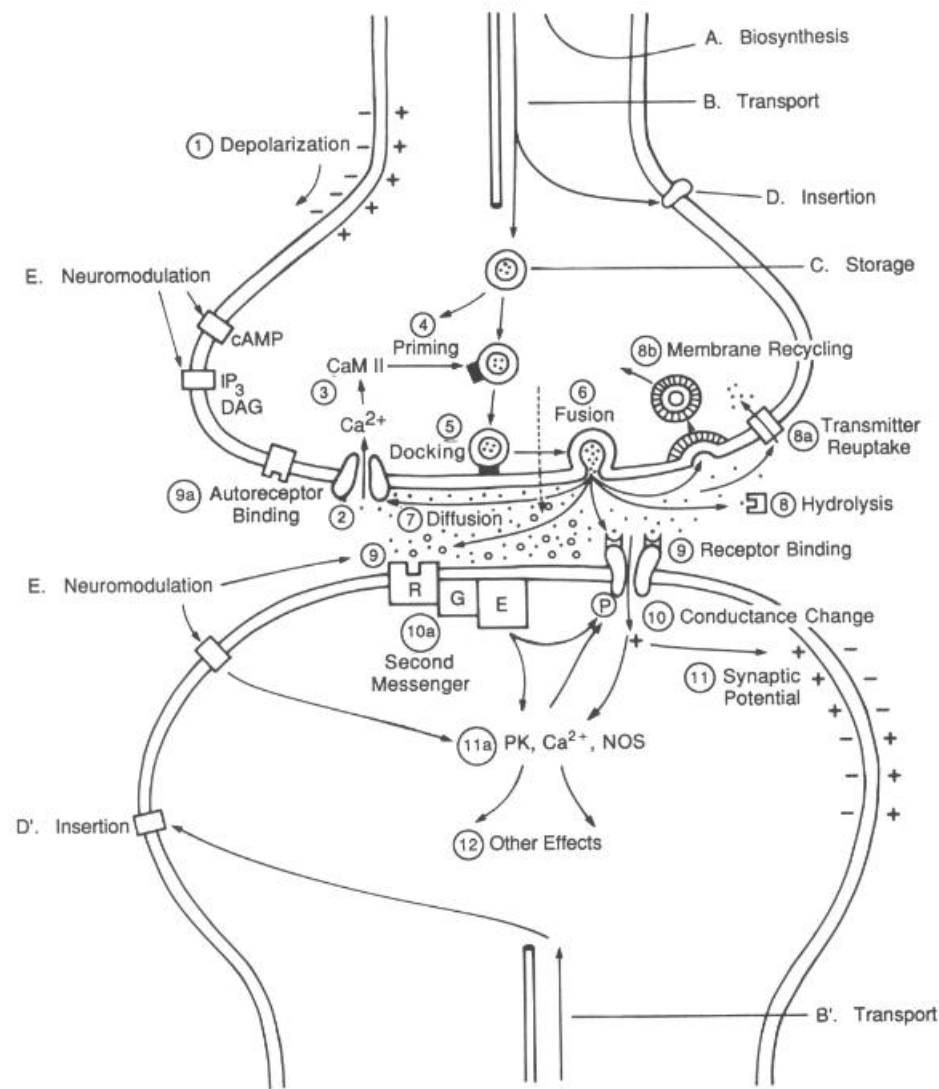

Gordon Shepherd, The Synaptic Organization of the Brain

Neurotransmitters

- A few neurotransmitters you should know about:

glutamate excitatory; pyramidal cells

GABA inhibitory interneurons

ACh neuromuscular junction (excit.)
 heart cells (muscarinic inhib.)
 hippocampus (modulatory)

- Dozens of substances can act as neurotransmitters , including both simple molecules (glutamate, GABA, ACh, dopamine, norepinephrine) and proteins (enkephalin, substance P.)
- Many kinds of channels can be sensitive to the same neurotransmitter.

Neurotransmitters (cont.)

- GABA = gamma aminobutyric acid
- GABA_A receptor: fast shunting inhibition via Cl⁻ channel.
- GABA_B receptor: slow, long-lasting inhibition via a K⁺ current. Not directly coupled to a single ion channel.
- Some receptors are named after substances that enhance or block their response (agonists/antagonists):
 - Muscarinic vs. nicotinic ACh receptors
 - NMDA vs. AMPA glutamate receptors
 - NMDA = N-methyl-d-aspartate
 - AMPA = α -amino-3-hydroxy-5-methyl-4-isoxazolepropionic acid

Ligand-Gated Ion Channels

- In the dendrites and soma there are receptors sensitive to particular neurotransmitters.
- In the simplest case, the receptor and ion channel are parts of the same complex. This is a *ligand-gated ion channel*.
- When transmitter binds to the receptor, the channel opens and ions flow.
- Whether a channel is excitatory or inhibitory depends on the kinds of ions it passes.
- For some inhibitory channels, binding of neurotransmitter *prevents* the channel from opening.

Ion Channels Are Proteins

Na⁺
channel

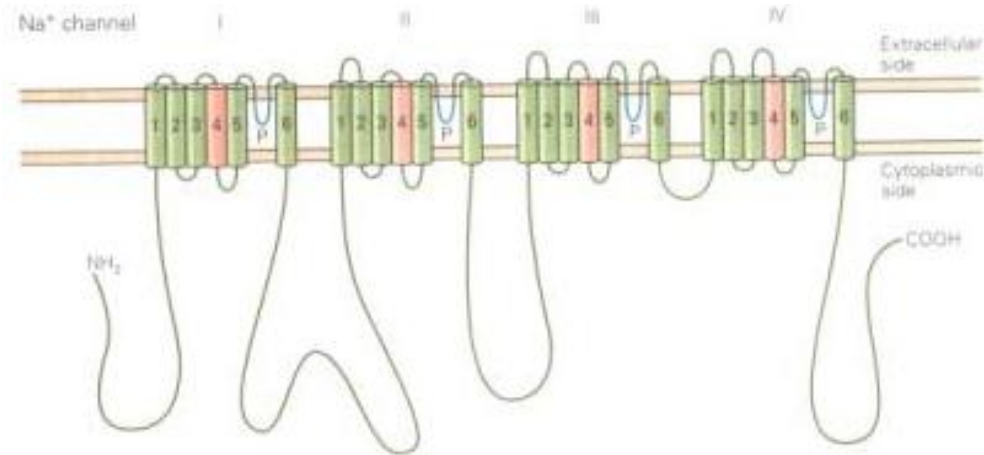

Ca²⁺
channel

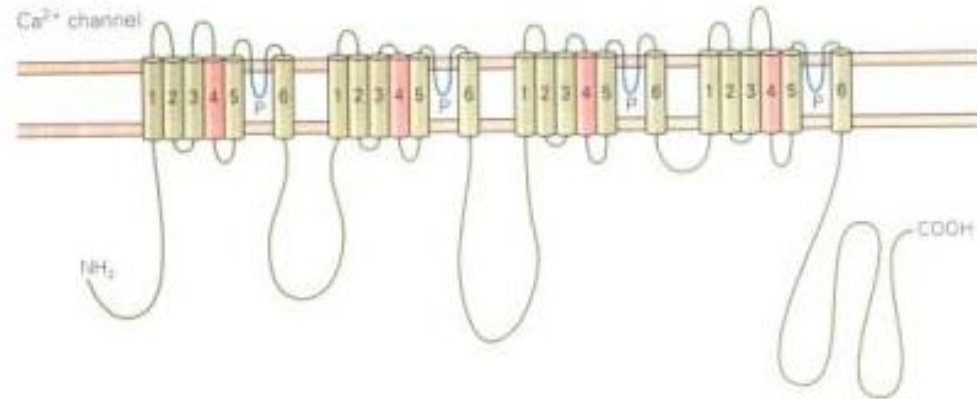

K⁺
channel

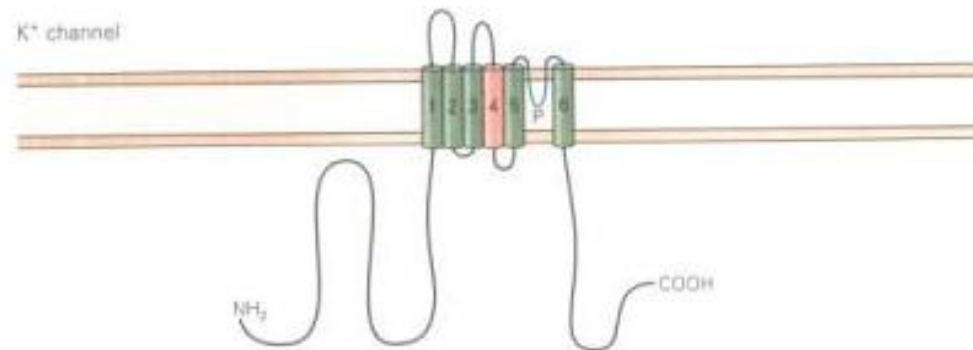

ACh Receptor

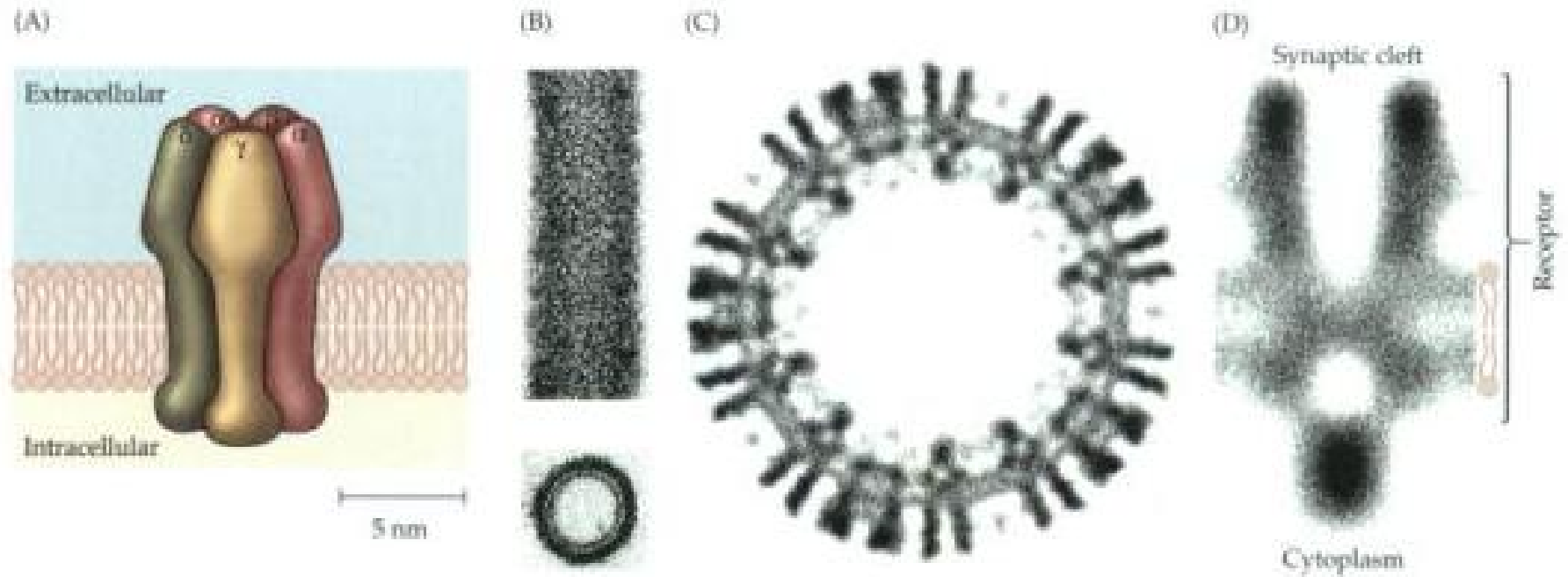

Ion Channels Are Proteins

- A channel is typically a single protein strand that passes through the membrane multiple times, forming a pore through which ions can pass.
- Modifications to the amino acid sequence result in slight changes to the channel characteristics, e.g., conductance, activation voltage, open/close time.
- Human and cow neurons both have ion channels, but their characteristics are slightly different.
- Cells continually make new channels and reclaim existing ones.
- By modulating the rates of creation and reclamation, a cell can dynamically adjust the distribution of channels over the surface of its membrane.
- Some types of *learning* may be implemented this way.

Second Messenger Systems

- Instead of being directly coupled to a channel, a receptor can be coupled to a G-protein.
- When transmitter binds to the receptor, this allows GDP (guanosine 5'-diphosphate) bound to the α subunit to be converted to GTP (guanosine 5'-triphosphate).
- The GTP- α subunit complex then detaches from the receptor and can interact with a variety of targets, including ion channels.
- This mechanism allows a single receptor to control several intracellular processes at once.
- The GABA_B receptor is an example of a second messenger system.

Second Messengers

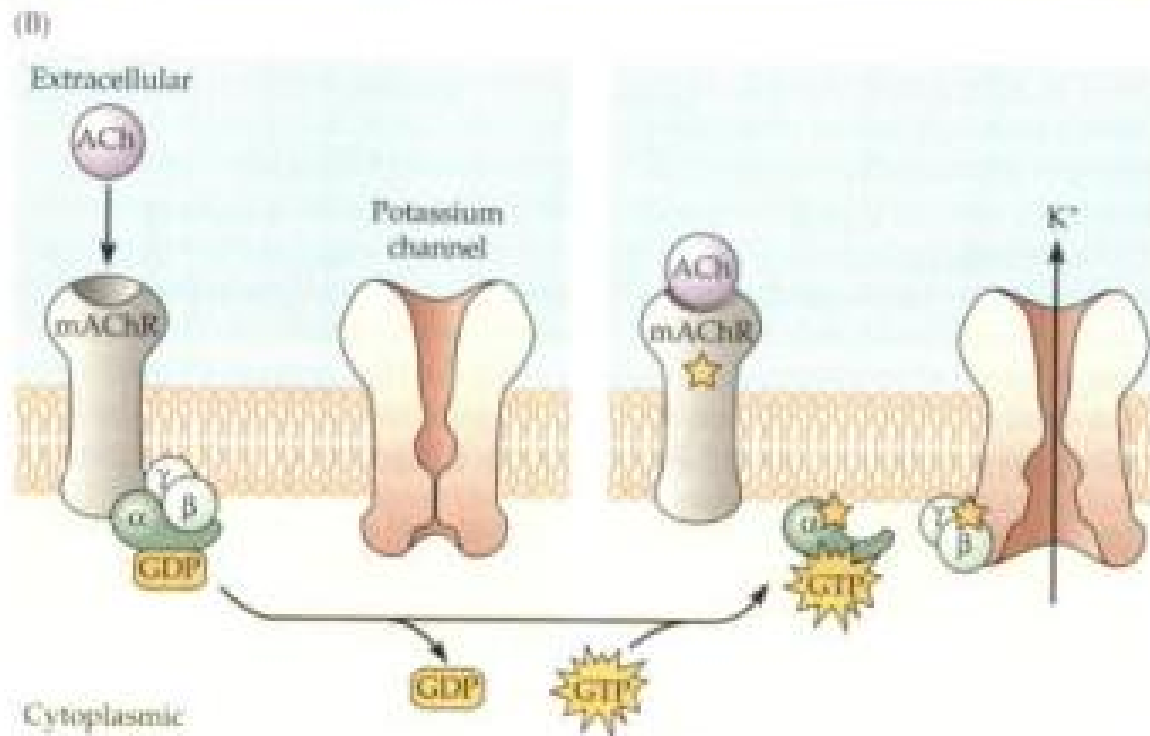
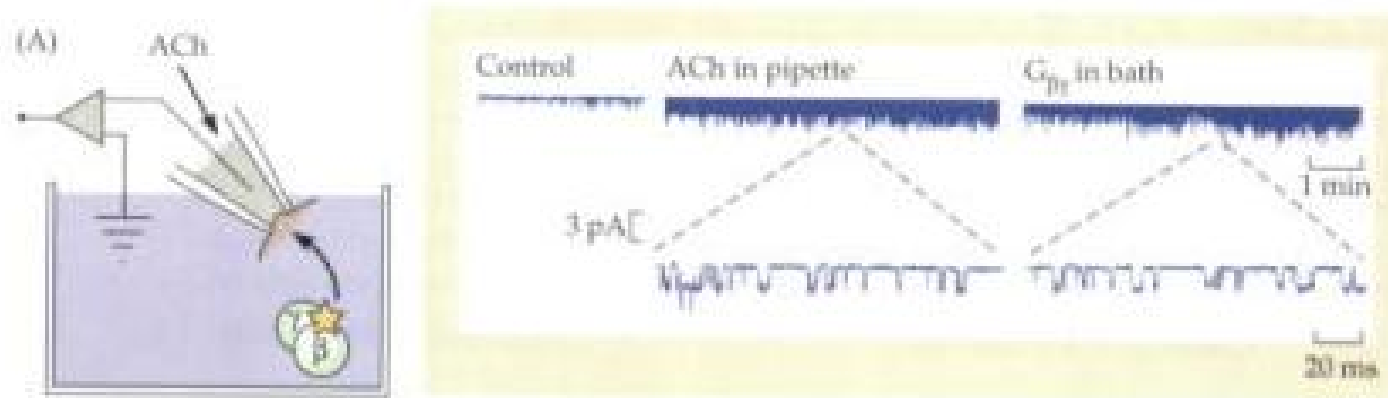

Properties of Dendrites

- Passive current flow? Can have Ca^{2+} spikes.
- The *cable equation* defines how current flows in dendritic segments.
 - Must deal with resistance, capacitance, multiple current sources, branched dendritic trees.
- Many synapses in the brain are made onto dendritic spines. Why are there spines?
 - small diameter neck gives high input impedance
 - mini-chemical reactors
- Spines can change shape with experience; another mechanism of learning?

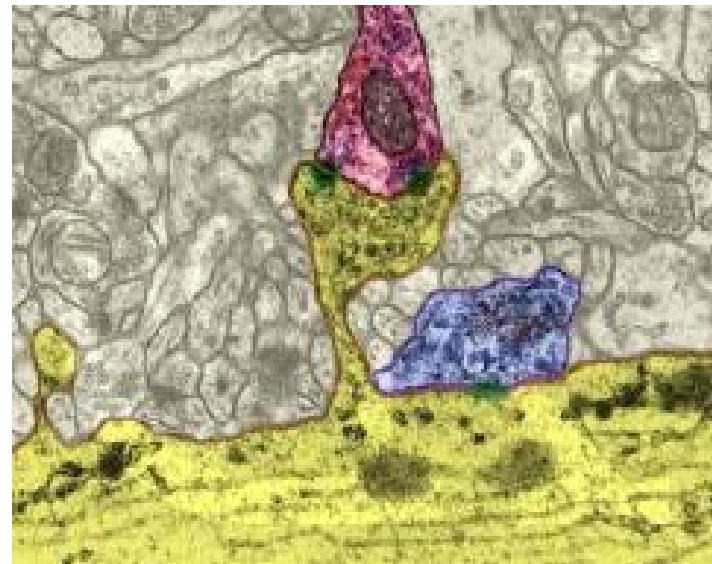

Dennis D. Kunkel; <http://www.pbrc.hawaii.edu/sfnhawaii/>

Dendritic Information Processing

- Local interactions in the dendritic tree are non-linear.
- Active membrane areas have been found in some dendrites, permitting dendritic spikes to occur.
- “Cold spots” are regions where shunting inhibition suppresses distal epsps, preventing them from traveling further toward the soma.
- AND gates, OR gates, and even AND-NOT gates are possible.
- What do neurons compute? Possibly very complex functions, since there can be 10,000 synapses coming into a pyramidal cell.

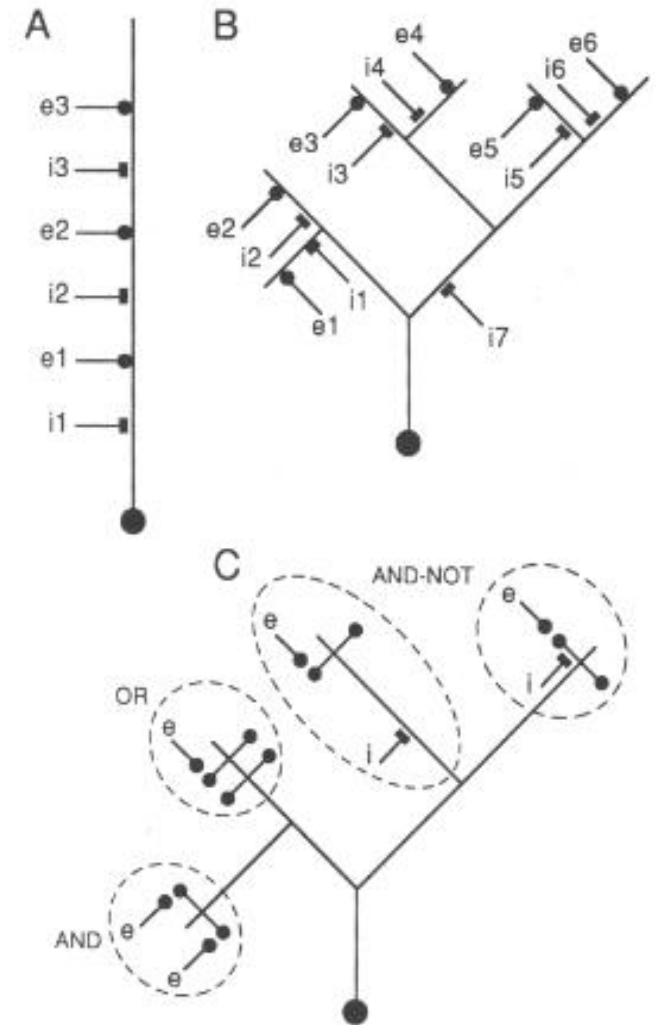

Gordon Shepherd, The Synaptic Organization of the Brain

Miscellaneous Items

- Terms to know:

epsp and *ipsp*
shunting inhibition

pyramidal cell
glutamate

GABA (γ -amino butyric acid)

GABA_A v. GABA_B receptor

- How neuroscientists draw pyramidal cells:

